

# BETRIEBSANLEITUNG

**EWT-80-40/-41**

**EWT-80-70/-71**

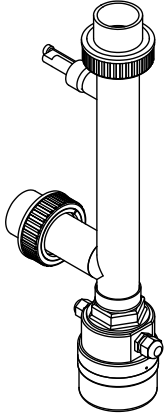

**Elektro Wärmetauscher**

Ihr **BEHNCKE**-Fachhändler:



## **BEHNCKE GmbH**

### **Bayern:**

Michael-Haslbeck Straße 13  
D-85640 Putzbrunn

Fon: +49 (0)89 / 45 69 17-0  
Fax: +49 (0)89 / 45 69 17-61

### **Sachsen-Anhalt:**

Stötterlinger Straße 36 a  
D-38835 Bühne

Fon: +49 (0)39421 / 796-0  
Fax: +49 (0)39421 / 796-30

**E-Mail:** [info@behncke.com](mailto:info@behncke.com)  
**Internet:** [www.behncke.com](http://www.behncke.com)

## Inhaltsverzeichnis

<b>1</b>	<b>Sicherheit</b>	<b>1</b>
1.1	Gefahren im Umgang mit diesem Elektro-Wärmetauscher	1
1.2	Sicherheitshinweise und Tips	1
1.3	Bestimmungsgemäße Verwendung	2
1.4	Gefahrenquellen	3
1.5	Sicherheitsmaßnahmen am Aufstellort	3
1.6	Sicherheitseinrichtungen	4
<b>2</b>	<b>Aufstellen und Installieren</b>	<b>5</b>
2.1	Transportieren/Lagern	5
1.7	Aufstellen	5
1.8	Installieren	5
2.2	Wasseranschluß	6
2.2.1	<i>Installationsanordnung oberhalb des Wasserspiegels</i>	6
2.2.2	<i>Installationsanordnung unterhalb des Wasserspiegels</i>	7
2.2.3	<i>Anschluß des Elektro-Wärmetauschers an den Wasserkreislauf einer Filteranlage</i>	8
2.2.4	<i>Allgemeine Einbauhinweise für den Strömungsschalter</i>	8
2.4	Elektrischer Anschluss	9
2.3	Strömungsschalter	9
<b>3</b>	<b>Funktionsablauf</b>	<b>10</b>
<b>4</b>	<b>Inbetriebnahme</b>	<b>10</b>
<b>5</b>	<b>Wartung / Instandhaltung</b>	<b>10</b>
5.1	Einwintern des EWT in frostfreien Räumen	11
5.2	Einwintern des EWT in frostgefährdeten Räumen	11
5.2.1	<i>Einwintern des EWT in frostfreien Räumen</i>	11
6.2.1	<i>Einwintern des EWT in frostfreien Räumen</i>	11
<b>6</b>	<b>Störungen und Abhilfe</b>	<b>11</b>
<b>7</b>	<b>Technische Abbildungen</b>	<b>Reiter: Technische Abbildungen</b>
<b>8</b>	<b>Konformitätserklärung</b>	<b>Reiter: Technische Abbildungen</b>

## 1 Sicherheit

### 1.1 Gefahren im Umgang mit diesem Elektro-Wärmetauscher

Der Elektro-Wärmetauscher ist nach dem Stand der Technik und den anerkannten sicherheitstechnischen Regeln gebaut. Dennoch können bei seiner Verwendung Gefahren entstehen und zwar

- Verletzung des Bedieners oder
- Dritter bzw.
- Beeinträchtigungen am Elektro-Wärmetauscher oder
- Beschädigung anderer Sachwerte.

Alle Personen, die mit der Installation, Inbetriebnahme, Bedienung, Wartung und Instandhaltung des Elektro-Wärmetauschers zu tun haben, müssen

- entsprechend qualifiziert sein.
- diese Installationsanweisung genau beachten.

Dieses Gerät ist nicht dafür bestimmt, durch Personen (einschließlich Kinder) mit eingeschränkten physikalischen, sensorischen oder geistigen Fähigkeiten oder mangels Erfahrung und/oder mangels Wissen benutzt zu werden, es sei denn, sie werden durch eine für ihre Sicherheit zuständige Person beaufsichtigt oder erhalten von ihr Anweisungen, wie das Gerät zu benutzen ist.

Der Elektro-Wärmetauscher ist nur zu benutzen





- für die bestimmungsgemäße Verwendung.
- in sicherheitstechnisch einwandfreiem Zustand.

Bei Störungen, welche die Sicherheit beeinträchtigen können, ist grundsätzlich eine Elektrofachkraft hinzuzuziehen.

In Räumen in denen elektrische Geräte in Funktion sind, sollte ein Rauchmelder installiert sein!

Es geht um Ihre Sicherheit.

### 1.2 Sicherheitshinweise und Tips

Symbol	Signalwort / Bedeutung
	<b>GEFAHR</b> Macht Sie auf eine gefährliche Situation aufmerksam, die eine schwere Verletzung oder den Tod nach sich ziehen wird, wenn sie nicht vermieden wird.
	<b>WARNUNG</b> Macht Sie auf eine möglicherweise gefährliche Situation aufmerksam die zum Tod oder zu schweren Verletzungen führen kann, wenn sie nicht vermieden wird.
	<b>VORSICHT</b> Macht Sie auf eine gefährliche Situation aufmerksam, die eine leichte bis mittelschwere Verletzung nach sich ziehen kann, wenn sie nicht vermieden wird.
	<b>HINWEIS</b> Macht Sie auf mögliche Sachschäden und andere wichtige Informationen aufmerksam.

Das Nichtbeachten dieses Hinweises kann zu Störungen an der Anlage oder in der Umgebung führen.

### 1.3 Bestimmungsgemäße Verwendung

Der Elektro-Wärmetauscher ist ausschließlich zur Erwärmung von Badewasser bei eingeschalteter Umwälz- oder Filterpumpe bestimmt.

Eine andere oder darüber hinausgehende Benutzung gilt als nicht bestimmungsgemäß. Für hieraus entstehende Schäden haftet der Hersteller BEHNCKE® GmbH nicht.

Eine anderweitige Verwendung ist nur nach Absprache und Genehmigung durch den Hersteller möglich.

	<p><b>HINWEIS!</b></p> <p>Zur bestimmungsgemäßen Verwendung gehört auch</p> <ul style="list-style-type: none"> <li>- das Beachten aller Hinweise der Installationsanweisung und</li> <li>- die Einhaltung der Inspektions- und Wartungsarbeiten</li> </ul> <p>Der maximal zulässige Betriebsüberdruck von 300 kPa (3 bar) darf nicht überschritten werden.</p> <p>Der minimal nötige Betriebsüberdruck von 10 kPa (0,1 bar) darf nicht unterschritten werden.</p> <p>Der Mindestdurchsatz beträgt 1000 l/h.</p>
---	---

**Es darf nur Wasser mit folgenden Werten verwendet werden:**

#### **EWT 80-40/-41, 80-70/-71**



Chloridgehalt	max. 500 mg/l
freies Chlor	max. 1,3 mg/l
pH	6,8 - 8,2
Langelier-Index	-0,3 – +0,3

**Der spezifische Wasserwiderstand darf nicht unter  $\leq 1100 \Omega \text{ cm}$  bei  $15^\circ\text{C}$  liegen.**

Umbauten und Veränderungen am Elektro-Wärmetauscher sind aus Sicherheitsgründen verboten.

Wartungs- und Reparaturarbeiten an den Rohrleitungen und der Elektroinstallation sind aus Sicherheitsgründen nur durch Fachpersonal vorzunehmen.



## 1.4 Gefahrenquellen

	<p><b>VORSICHT!</b></p> <p><b>Der Elektro-Wärmetauscher kann beschädigt werden.</b></p> <p>Bei Überschreiten des max. Betriebsüberdruck von 300 kPa (3,0 bar) kann der Elektro-Wärmetauscher undicht werden.</p>
	<p><b>VORSICHT!</b></p> <p><b>Es besteht Verbrennungsgefahr.</b></p> <p>Die Anschlüsse und der Elektro-Wärmetauscher können Temperaturen bis 100°C erreichen.</p> <p>Bei nicht ausreichendem Wasserdurchfluß (&lt; 1000 l/h) ist eine starke Überhitzung des Elektro-Wärmetauschers möglich.</p> <p>Der Einbau eines Strömungswächters als weitere Sicherheitseinrichtung wird grundsätzlich empfohlen.</p>
	<p><b>VORSICHT!</b></p> <p><b>Der Elektro-Wärmetauscher kann beschädigt werden.</b></p> <p>Durch Tropfwasser auf die Außenhaut oder bei Einschwemmen von Metallteilen in den Elektro-Wärmetauscher besteht die Gefahr der Kontaktkorrosion.</p>

## 1.5 Sicherheitsmaßnahmen am Aufstellort

Der Elektro-Wärmetauscher muß in einem frostsicheren Raum mit einer Edelstahl bzw. Kunststoff-Halterung montiert werden.

Stellen Sie sicher, daß der maximale Betriebsdruck von 300 kPa (3,0 bar) nicht überschritten wird.

	<p><b>VORSICHT!</b></p> <p>Der Elektro-Wärmetauscher oder die Umgebung kann Schaden nehmen.</p> <p>Überprüfen Sie während des Badebetriebs mindestens einmal pro Woche den Elektro-Wärmetauscher und seine Anschlüsse auf Dichtigkeit und äußerlich erkennbare Schäden.</p>
	<p><b>VORSICHT!</b></p> <p><b>Es besteht Brandgefahr.</b></p> <p>Bei nicht ausreichendem Wasserdurchfluß (&lt; 1000 l/h) ist eine starke Überhitzung des Elektro-Wärmetauschers möglich.</p> <p>Lagern Sie keine brennbaren Materialien in der Umgebung.</p> <p>Der Einbau eines Strömungswächters als weitere Sicherheitseinrichtung wird grundsätzlich empfohlen.</p> <p>Er verhindert zusätzlich ein Durchbrennen des Heizwiderstandes bei Wasserstillstand.</p>

	<p><b>VORSICHT!</b></p> <p><b>Der Elektro-Wärmetauscher kann beschädigt werden.</b></p> <p>Der Elektro-Wärmetauscher darf nur in Betrieb genommen werden, wenn sichergestellt ist, daß während des Betriebs der Elektro-Wärmetauscher ständig mit Wasser versorgt wird. Der Wasserdurchsatz muß mindestens 1000 l/h betragen.</p>
---	---

## 1.6 Sicherheitseinrichtungen

Das Warnschild am Elektro-Wärmetauscher weist auf die Gefahren durch elektrischen Strom hin.

Der Elektro-Wärmetauscher ist mit einem Sicherheits-Druckbegrenzer ausgestattet.

Der Sicherheits-Druckbegrenzer dient als Wassermangel-Sicherung (siehe EWT 80-40 bzw. -70).

	<p><b>VORSICHT!</b></p> <p>Der Elektro-Wärmetauscher muß durch mindestens zwei Sicherheits-Abschalter geschützt werden.</p> <p>Werkseitig werden folgende Kombinationen angeboten</p> <ul style="list-style-type: none"> <li>- mit einem Sicherheits-Temperaturbegrenzer</li> <li>- mit einem Regelthermostat und einem Sicherheits-Temperaturbegrenzer (STB)</li> <li>- mit einem Regelthermostat, einem STB und einem Strömungsschalter</li> <li>- mit einem Schütz bis 12 kW.</li> </ul>
---	---

Falls werkseitig kein Schütz installiert ist, ist ein externer Schütz zum Schalten des Heizstabes notwendig (z. B. Behncke ®-Steuerung für EWT 80-xx).

Steuerung mit einem Schütz:	3–12 kW	Art.Nr. 304 006 12
	15–18 kW	Art.Nr. 304 006 18

Steuerung mit eingebautem zweiten Schütz für Sicherheitsabschaltung mit Kontrolllampe (dringend empfohlen) für EWT 80-41/-71 mit Regel und Sicherheitsthermostat:

	3–12 kW	Art.Nr. 304 007 12
	15–18 kW	Art.Nr. 304 007 18

– Schaltkasten im Lieferumfang nicht enthalten! –

Die Sicherheitseinrichtungen schalten bei Erreichen unzulässiger Werte den Elektrowärmetauscher ab.

## 2 Aufstellen und Installieren

### 2.1 Transportieren/Lagern

Transportieren Sie den Elektro-Wärmetauscher nur entleert.



Lagern Sie den gespülten und entleerten Elektro-Wärmetauscher nur in Innenräumen mit nicht-aggressiver Atmosphäre.

### 1.7 Aufstellen

Stellen Sie den Elektro-Wärmetauscher nur in frostsicheren, trockenen Räumen mit nicht-aggressiver Atmosphäre auf.

Tropfwasser kann den Elektro-Wärmetauscher beschädigen.

Gewährleisten Sie die leichte Zugänglichkeit für die Montage und Demontage.

	<p><b>VORSICHT!</b></p> <p>Für den Elektro-Wärmetauscher sind folgende Wasserwerte unbedingt einzuhalten.</p> <p><b>EWT 80-40/-41, 80-70/-71</b></p> <table><tr><td>Chloridgehalt</td><td>max. 500 mg/l</td></tr><tr><td>freies Chlor</td><td>max. 1,3 mg/l</td></tr><tr><td>pH</td><td>6,8 - 8,2</td></tr><tr><td>Langelier-Index</td><td>-0,3 – +0,3</td></tr><tr><td>Wasserdurchsatz</td><td>min. 1000 l/h</td></tr><tr><td>min. Betriebsdruck</td><td>10 kPa (0,1 bar)</td></tr><tr><td>max. Betriebsdruck</td><td>300 kPa (3,0 bar)</td></tr></table>	Chloridgehalt	max. 500 mg/l	freies Chlor	max. 1,3 mg/l	pH	6,8 - 8,2	Langelier-Index	-0,3 – +0,3	Wasserdurchsatz	min. 1000 l/h	min. Betriebsdruck	10 kPa (0,1 bar)	max. Betriebsdruck	300 kPa (3,0 bar)
Chloridgehalt	max. 500 mg/l														
freies Chlor	max. 1,3 mg/l														
pH	6,8 - 8,2														
Langelier-Index	-0,3 – +0,3														
Wasserdurchsatz	min. 1000 l/h														
min. Betriebsdruck	10 kPa (0,1 bar)														
max. Betriebsdruck	300 kPa (3,0 bar)														
	<p><b>VORSICHT!</b></p> <p>Bei Ausfall der Sicherheits-Einrichtungen besteht Brandgefahr.</p> <p>Die Überhitzung des Elektro-Wärmetauschers kann einen Brand verursachen.</p> <p>Ein Leerlaufen des Elektro-Wärmetauschers im Betrieb muss verhindert werden.</p> <p>Lagern Sie keine brennbaren Materialien in der Umgebung.</p>														

### 1.8 Installieren

Vor der Installation ist zu prüfen, dass der Elektro-Wärmetauscher keine sichtbaren Beschädigungen aufweist.

Der Elektro-Wärmetauscher kann horizontal oder vertikal oberhalb oder unterhalb des Wasserspiegels installiert werden.

Bei Installation ober- bzw. unterhalb 0,50 m des Wasserspiegels verliert der Sicherheits-Druckschalter (Wassermangelsicherung) seine Wirksamkeit.

In diesem Fall ist anstatt des Druckschalters ein Behncke ®-Strömungsschalter unbedingt erforderlich. (siehe EWT 80-41/-71)

## 2.2 Wasseranschluß

### 2.2.1 Installationsanordnung oberhalb des Wasserspiegels



Abbildung: Horizontaler Einbau (EWT 80-40/-70)



Abbildung: Horizontaler Einbau (EWT 80-41/-71)

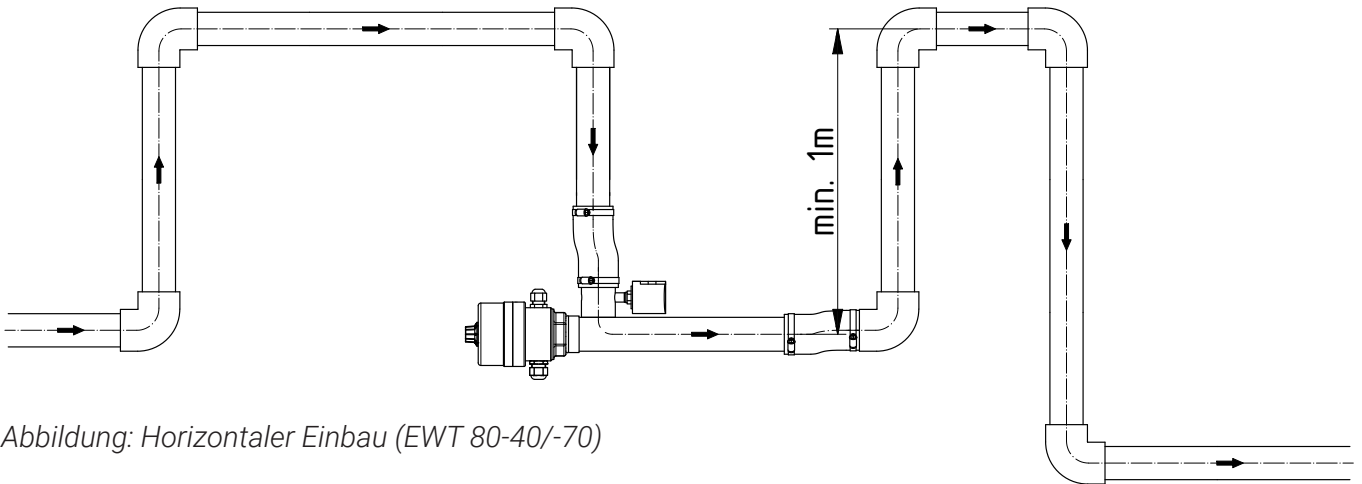

Abbildung: Vertikaler Einbau (EWT 80-40/-70)



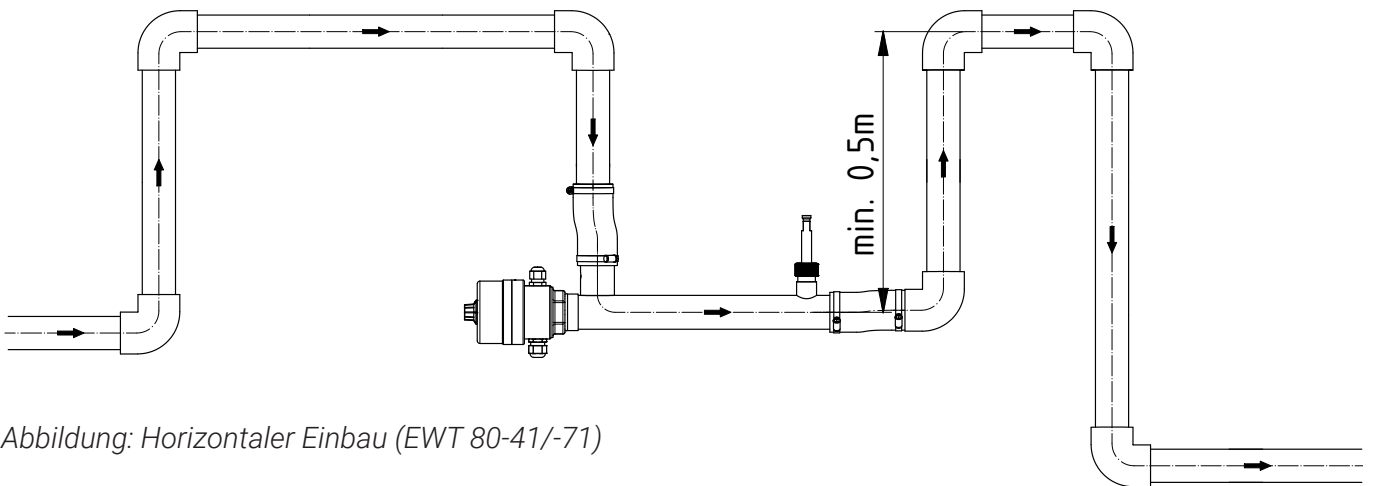

### 2.2.3 Anschluß des Elektro-Wärmetauschers an den Wasserkreislauf einer Filteranlage

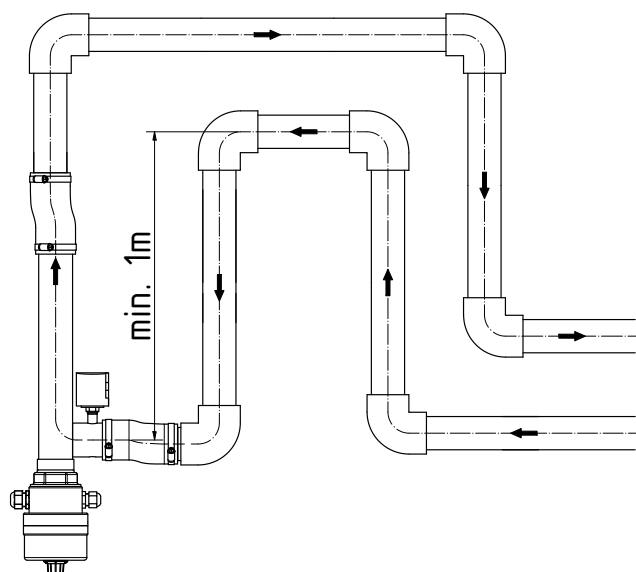
Bauen Sie den Elektro-Wärmetauscher in der Druckleitung (zum Becken) nach Pumpe und Filter ein.

Der EWT 80-40/-41 wird über die Innengewinde 1 1/2" oder über Schlauchverbindungen mit Schlauchklemmen in den Wasserkreislauf eingebunden.

Der EWT 80-70/-71 wird mit PVC-Klebeverschraubungen d50 in den Wasserkreislauf eingebunden.

	<p><b>VORSICHT!</b></p> <p>Der Elektro-Wärmetauscher kann beschädigt werden.</p> <p>Beim Anschluß an den Wasserkreislauf ist darauf zu achten, daß keine Metallteile in den Elektro-Wärmetauscher eingetragen werden.</p>
	<p><b>VORSICHT!</b></p> <p><b>Der Elektro-Wärmetauscher kann durch Chemikalien beschädigt werden.</b></p> <p>Entkeimungsgeräte sind grundsätzlich in Flußrichtung nach dem Elektro-Wärmetauscher zu installieren. Der Abstand muß mindestens 1 m betragen und die Reihenfolge: erst Härteregelung, dann Chlorimpfung, ist einzuhalten.</p> <p>Bei Verwendung von Chemikalien (z. B. Chlorgas) dürfen während der Filterstillstandszeiten keine Gase in den Elektro-Wärmetauscher eindringen.</p>

### 2.2.4 Allgemeine Einbauhinweise für den Strömungsschalter

Die Beruhigungsstrecke muss vor und hinter dem Strömungskontrollschalter mindestens 5 x DN betragen.

**Der Strömungskontrollschalter darf nur in eine waagrechte Leitung eingebaut werden.**

Bei abweichenden Einbauanlagen müssen Sie den Hersteller befragen.

Die Schalter sollten Sie nur senkrecht stehend einbauen, Abweichung max. 45° (siehe Abb. 1).

Sorgen Sie dafür, daß in der unmittelbaren Umgebung des Strömungskontrollschalters keine magnetischen Fremdfelder die Funktionsweise des Gerätes beeinträchtigen können (siehe Abb. 2).

Auf dem Strömungskontrollschalter befindet sich ein Pfeil. Achten Sie beim Einbau darauf, dass dieser unbedingt parallel mit der Rohrachse läuft und in Strömungsrichtung zeigt (siehe Abb. 3).

Die Überwurfmutter G 3/4 aus Kunststoff müssen Sie mit einem max. Anzugsmoment von 8 Nm anziehen.



Abb. 1



Abb. 2



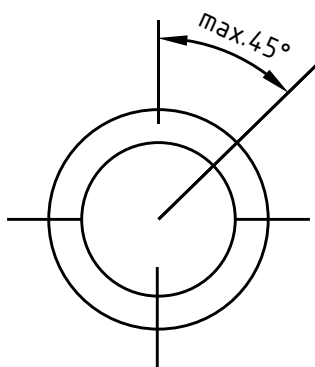

Abb. 3

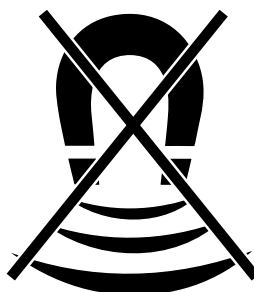
## 2.4 Elektrischer Anschluss

	<p><b>ELEKTRISCHE SPANNUNG!</b></p> <p>Der elektrische Anschluß darf nur durch eine Elektrofachkraft vorgenommen werden. Dabei sind die örtlichen Vorschriften sowie die VDE 0100 zu berücksichtigen. Der Wärmetauscher muss dauerhaft an festverlegte Leitungen mit Schutzleiter angeschlossen werden.</p>
	<p><b>VORSICHT!</b></p> <p><b>Der Elektro-Wärmetauscher muß durch mindestens zwei Sicherheits-Abschalter geschützt werden.</b></p> <p>Werkseitig werden folgende Kombinationen angeboten</p> <ul style="list-style-type: none"><li>– mit einem Regelthermostat</li><li>– mit einem Regelthermostat und einem Sicherheits-Temperaturbegrenzer (STB)</li><li>– mit einem Regelthermostat, einem STB und einem Strömungsschalter.</li><li>– mit einem Schütz bis 12 kW.</li></ul> <p>Falls werkseitig kein Schütz installiert ist, ist ein externer Schütz zum Schalten des Heizstabes notwendig (z. B. Behncke-Steuerung für EWT 80-xx)</p>
	<p><b>HINWEIS!</b></p> <p>Es muss sichergestellt sein, dass der Elektro-Wärmetauscher nur bei sichergestellter Durchströmung eingeschaltet werden kann.</p> <p>Die elektrischen Anschlüsse sind laut Schaltbild vorzunehmen.</p> <p>Aus Sicherheitsgründen ist in die Spannungsversorgung ein FI-Schutzschalter (30 mA) einzubauen. Alle Metallteile sind in den Potentialausgleich einzubeziehen.</p>

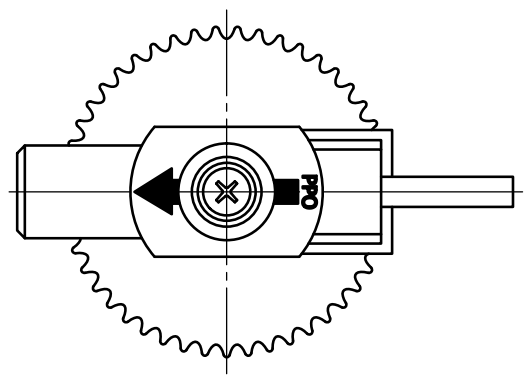
## 2.3 Strömungsschalter

	<p><b>VORSICHT!</b></p> <p><b>Lebensgefahr durch elektrische Spannung!</b></p> <p>Schalten Sie die elektrische Anlage spannungsfrei, bevor Sie die Litzen der Anschlussleitung anschließen.</p> <p>braun/schwarz = Anschlüsse für den Reedkontakt</p> <p>Der Reedkontakt ist schutzisoliert (Schutzklasse II) in einer Kunststoffhülse integriert.</p>
	<p><b>VORSICHT!</b></p> <p><b>Lebensgefahr durch elektrische Spannung!</b></p> <p>Die auf dem Typenschild angegebene max. elektrische Kontaktbelastung darf in keinem Fall überschritten werden, da sonst der in der Schalteinheit integrierte Reedkontakt beschädigt wird. Bei induktiven Lasten verringert sich das Schaltleistungsvermögen. Angaben zur Schutzbeschaltung können beim Herstellerwerk erfragt werden.</p>

### 3 Funktionsablauf

Im Elektro-Wärmetauscher wird durch den Heizstab Wärme an das Badewasser übertragen.

Der Thermostat regelt die Wasser-Temperatur auf die eingestellte Höhe, Einstellbereich: 0 bis 40°C.

EWT 80-40/-70: Sinkt der erforderliche Betriebsüberdruck wegen mangelnder Durchströmung unter 6 kPa (0,06 bar), schaltet der Sicherheits-Druckbegrenzer den Elektro-Wärmetauscher ab.

EWT 80-41/-71: Sinkt der erforderliche Betriebsüberdruck wegen mangelnder Durchströmung unter 36,0 l/min., schaltet der Strömungsschalter den EWT ab.

Option: Sicherheits-Thermostat

Vor Überhitzung schützt der Sicherheits-Temperaturbegrenzer. Er schaltet bei einer Temperatur von 44°C den Elektro-Wärmetauscher ab.

Durch Drücken des Entstörknopfes kann der Elektro-Wärmetauscher nach Beseitigung einer Störung wieder in die normale Betriebsbereitschaft versetzt werden.

### 4 Inbetriebnahme

Haben Sie diese Betriebsanleitung - insbesondere Kapitel 1, Sicherheit - gelesen und verstanden? Sie dürfen den Elektro-Wärmetauscher vorher nicht in Betrieb nehmen!

- Stellen Sie am Thermostat die gewünschte Badewasser-Temperatur ein.

So lange die eingestellte Temperatur nicht erreicht ist, beheizt der Elektro-Wärmetauscher das Badewasser.



#### **VORSICHT!**

##### **Der Elektro-Wärmetauscher kann beschädigt werden.**

Arbeiten an den Rohrleitungen und der Elektroinstallation sind aus Sicherheitsgründen nur durch Fachpersonal vorzunehmen.

Steigen Sie nicht auf den Elektro-Wärmetauscher.

Führen Sie Wartungs- und Reinigungsarbeiten nur bei geschlossenen Absperrorganen mit Wasserkreislauf durch!

Entlüften Sie den gesamten Wasserkreislauf, ansonsten kann das Heizelement schaden nehmen.

### 5 Wartung / Instandhaltung

Prüfen Sie wöchentlich den Elektro-Wärmetauscher und die Anschlüsse auf Dichtigkeit und Entlüften Sie den gesamten Wasserkreislauf.



#### **VORSICHT!**

##### **Der Elektro-Wärmetauscher kann beschädigt werden.**

Arbeiten am Elektro-Wärmetauscher sind aus Sicherheitsgründen nur durch Fachpersonal vorzunehmen.

Steigen Sie nicht auf den Elektro-Wärmetauscher.

Arbeiten an den Rohranschlüssen dürfen nur bei geschlossenen Absperrorganen im Wasserkreisläufen durchgeführt werden!

## 5.1 Einwintern des EWT in frostfreien Räumen

	<p><b>VORSICHT!</b></p> <p>Eingriffe an technischen Anlagen durch unkundige Personen können zu Verletzungen und zu Sachbeschädigung führen.</p> <p>Bei Stilllegung in frostfreien Räumen muß der Elektro-Wärmetauscher komplett mit Wasser gefüllt oder komplett entleert sein.</p>
---	---

## 5.2 Einwintern des EWT in frostgefährdeten Räumen

	<p><b>VORSICHT!</b></p> <p>Die sachgerechte Überwinterung ohne Frostschäden ist bei Beachten der folgenden Arbeitsschritte möglich.</p> <ul style="list-style-type: none"> <li>• Absperrorgane im Wasserkreislauf schließen. (Absperrorgane müssen in frostfreien Räumen installiert sein.)</li> <li>• Elektro-Wärmetauscher und anschließende Rohrleitungen bis zu den Absperrorganen durchspülen und entleeren.</li> </ul>
---	--

### 5.2.1 Elektro-Wärmetauscher in vertikaler Anordnung

Elektro-Wärmetauscher über Entleerungsarmaturen komplett entleeren.

### 6.2.1 Einwintern des EWT in horizontaler Anordnung

Elektro-Wärmetauscher in horizontaler Anordnung ausbauen.

Elektro-Wärmetauscher durchspülen, um Verunreinigungen zu entfernen, und trocken lagern.

## 6 Störungen und Abhilfe

Fehler	Prüfen der möglichen Ursache
Keine Leistung	<p>Ist der Elektro-Wärmetauscher elektrisch angeschlossen? Sind die Absperrorgane im Wasserkreislauf geöffnet?</p> <p>Ist der Elektro-Wärmetauscher komplett mit Wasser gefüllt?</p> <p>Wurde der Elektro-Wärmetauscher entlüftet?</p>
Elektro-Wärmetauscher wird weiter aufgeheizt, trotz abgeschalteter BadewasserUmwälzpumpe	<p>Wird der Elektro-Wärmetauscher ausreichend von Wasser durchströmt (siehe Technische Daten)?</p> <p>Ist die Verriegelung zwischen Badewasser-Pumpe und Elektro-Wärmetauscher aktiv?</p>

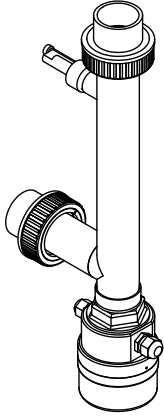

# INSTRUCTION MANUAL

**EWT-80-40/-41**

**EWT-80-70/-71**

**Electric heat exchanger**



## **BEHNCKE GmbH**

### **Bavaria:**

Michael-Haslbeck Straße 13  
D-85640 Putzbrunn

Phone: +49 (0)89 / 45 69 17-0

Fax: +49 (0)89 / 45 69 17-61

### **Saxony-Anhalt:**

Stötterlinger Straße 36 a  
D-38835 Bühne

Phone: +49 (0)39421 / 796-0

Fax: +49 (0)39421 / 796-30

**Email:** [info@behncke.com](mailto:info@behncke.com)

**Website:** [www.behncke.com](http://www.behncke.com)

## **Contents**

<b>1</b>	<b>Safety</b>	<b>1</b>
1.1	Dangers when handling this electric heat exchanger	1
1.2	Safety information and tips	1
1.3	Proper use	2
1.4	Sources of danger	3
1.5	Safety measures at the installation site	3
1.6	Safety devices	4
<b>2</b>	<b>Setting up and installation</b>	<b>5</b>
2.1	Transportation / storage	5
2.2	Set up	5
2.3	Installation	5
2.4	Water connection	6
2.4.1	<i>Installation arrangement above the water level</i>	6
2.4.2	<i>Installation arrangement below the water level</i>	7
2.4.3	<i>Connecting the electric heat exchanger to the water circuit of a filter system</i>	8
2.4.4	<i>General installation instructions for the flow switch</i>	8
2.5	Electrical connection	9
2.6	Flow switch	9
<b>3</b>	<b>Functional sequence</b>	<b>10</b>
<b>4</b>	<b>Start-up</b>	<b>10</b>
<b>5</b>	<b>Maintenance / servicing</b>	<b>10</b>
5.1	Storing the electric heat exchanger over winter in frost-free rooms	11
5.2	Storing the electric heat exchanger over winter in spaces at risk of frost	11
5.2.1	<i>Electric heat exchanger in a vertical position</i>	11
5.2.2	<i>Storing the electric heat exchanger over winter in a horizontal position</i>	11
<b>6</b>	<b>Faults and corrections</b>	<b>11</b>
<b>7</b>	<b>Technical illustrations</b>	<b>Index: Technical illustrations</b>
<b>8</b>	<b>Declaration of conformity</b>	<b>Index: Technical illustrations</b>

# 1 Safety

## 1.1 Dangers when handling this electric heat exchanger

The electric heat exchanger is state-of-the-art and has been built in accordance with recognised safety regulations. Nevertheless, hazards can arise when it is being used, namely

- injury to the operator or
- third parties or
- damage to the electric heat exchanger or
- damage to other property.

Anyone involved with the installation, start-up, operation, maintenance and servicing of the electric heat exchanger must

- be appropriately qualified.
- strictly follow these installation instructions.

This appliance is not intended to be used by people (including children) with reduced physical, sensory or mental capabilities, or people who lack experience and/or knowledge unless they have been given supervision or instructions concerning use of the appliance by a person responsible for their safety.

The electric heat exchanger may only be used





- for its intended use.
- when it is in perfect condition from a safety and technical perspective.

In the event of faults which may compromise safety, you must call in an electrician.

A smoke detector must be installed in rooms where electrical appliances are in operation!

It's about your safety.

## 1.2 Safety information and tips

Symbol	Signal word / meaning
	<b>DANGER</b> Alerts you to a dangerous situation that will result in serious injury or death if it is not avoided.
	<b>WARNING</b> Alerts you to a potentially dangerous situation that may lead to death or severe injury if it is not avoided.
	<b>CAUTION</b> Alerts you to a dangerous situation that will result in minor to moderate injury if it is not avoided.
	<b>NOTE</b> Alerts you to possible material damage and other important information.

Failure to observe these instructions may lead to faults in the system or in the environment.

### 1.3 Proper use

The electric heat exchanger is intended exclusively for heating pool water when the circulation or filter pump is switched on.

Any other use or use that goes beyond this is considered improper use. The manufacturer, BEHNCKE® GmbH, is not liable for any damage resulting from this.

Other uses are only possible following consultation with and approval from the manufacturer.



#### NOTE!

Proper use also includes

- observing all the instructions in the installation instructions and
- complying with inspection and maintenance works

The maximum permissible positive operating pressure of 300 kPa (3 bar) must not be exceeded.

The positive operating pressure must not fall below the minimum required positive operating pressure of 10 kPa (0.1 bar).

The minimum flow rate is 1000 l/h.

**Only water with the following values may be used:**

#### EWT 80-40/-41, 80-70/-71



Chloride content	max. 500 mg/l
Free chlorine	max. 1.3 mg/l
pH	6.8 - 8.2
Langelier index	-0.3 – +0.3

**The specific water resistance must not be less than  $\leq 1,100 \Omega \text{ cm}$  at 15°C.**

Modifications and alterations to the electric heat exchanger are forbidden for safety reasons.



For safety reasons, maintenance and repairs to the pipelines and the electrical installation may only be carried out by qualified personnel.

### 1.4 Sources of danger

	<p><b>CAUTION!</b></p> <p><b>The electric heat exchanger may be damaged.</b></p> <p>If the maximum positive operating pressure of 300 kPa (3.0 bar) is exceeded, the electric heat exchanger may leak.</p>
	<p><b>CAUTION!</b></p> <p><b>There is a risk of burning.</b></p> <p>The connections and the electric heat exchanger can reach temperatures of up to 100°C.</p> <p>If the water flow is insufficient (&lt; 1000 l/h), the electric heat exchanger may seriously overheat.</p> <p>The installation of a flow monitor as an additional safety device is generally recommended.</p>
	<p><b>CAUTION!</b></p> <p><b>The electric heat exchanger may be damaged.</b></p> <p>Contact corrosion is a risk due to water dripping onto the outer skin or when metal parts are washed into the electric heat exchanger.</p>

### 1.5 Safety measures at the installation site

The electric heat exchanger must be installed in a frost-proof room with a stainless steel or plastic bracket. Make sure that the maximum operating pressure of 300 kPa (3.0 bar) is not exceeded.

	<p><b>CAUTION!</b></p> <p>The electric heat exchanger and its surroundings may be damaged.</p> <p>Check the electric heat exchanger and its connections for leaks and visible damage at least once a week while the pool is in use.</p>
	<p><b>CAUTION!</b></p> <p><b>There is a risk of fire.</b></p> <p>If the water flow is insufficient (&lt; 1000 l/h), the electric heat exchanger may seriously overheat.</p> <p>Do not store flammable materials nearby.</p> <p>The installation of a flow monitor as an additional safety device is generally recommended.</p> <p>This also prevents the heating resistor from burning out when the water stops.</p>

**CAUTION!****The electric heat exchanger may be damaged.**

The electric heat exchanger may only be put into operation if it is ensured that the electric heat exchanger will be continuously supplied with water during operation. The water flow rate must be at least 1000 l/h.

**1.6 Safety devices**

The warning sign on the electric heat exchanger indicates there are risks due to the electric current.

The electric heat exchanger is equipped with a safety pressure limiter.

The safety pressure limiter serves as a low-water protection (see EWT 80-40 or -70).

**CAUTION!**

The electric heat exchanger must be protected by at least two safety switches.

The following combinations are on offer ex works

- with a safety temperature limiter
- with a control thermostat and a safety temperature limiter (STL)
- with a control thermostat, a safety temperature limiter and a flow switch
- with a contactor up to 12 kW.

If no contactor is installed at the factory, an external contactor is required to switch the heating rod (e.g. Behncke ® control system for EWT 80-xx).

Control system with one contactor:	3–12 kW	Item no. 304 006 12
	15–18 kW	Item no. 304 006 18

Control system with built-in second contactor for safety shutdown with pilot light (strongly recommended) for EWT 80-41/-71 with control and safety thermostat:

	3–12 kW	Item no. 304 007 12
	15–18 kW	Item no. 304 007 18

– Switch box not included in the delivery! –

The safety devices switch off the electric heat exchanger when impermissible values are reached.

## 2 Setting up and installation

### 2.1 Transportation / storage

Only transport the electric heat exchanger when it is empty.



Only store the rinsed and drained electric heat exchanger inside rooms with a non-aggressive atmosphere.

### 2.2 Set up

Only install the electric heat exchanger in frost-proof, dry rooms with a non-aggressive atmosphere.

Dripping water may damage the electric heat exchanger.

Ensure ease of access for assembly and disassembly.

	<p><b>CAUTION!</b></p> <p>The following water values must be observed for the electric heat exchanger.</p> <p><b>EWT 80-40/-41, 80-70/-71</b></p> <table><tr><td>Chloride content</td><td>max. 500 mg/l</td></tr><tr><td>Free chlorine</td><td>max. 1.3 mg/l</td></tr><tr><td>pH</td><td>6.8 - 8.2</td></tr><tr><td>Langelier index</td><td>-0.3 – +0.3</td></tr><tr><td>Water flow rate</td><td>min. 1,000 l/h</td></tr><tr><td>Min. operating pressure</td><td>10 kPa (0.1 bar)</td></tr><tr><td>Max. operating pressure</td><td>300 kPa (3.0 bar)</td></tr></table>	Chloride content	max. 500 mg/l	Free chlorine	max. 1.3 mg/l	pH	6.8 - 8.2	Langelier index	-0.3 – +0.3	Water flow rate	min. 1,000 l/h	Min. operating pressure	10 kPa (0.1 bar)	Max. operating pressure	300 kPa (3.0 bar)
Chloride content	max. 500 mg/l														
Free chlorine	max. 1.3 mg/l														
pH	6.8 - 8.2														
Langelier index	-0.3 – +0.3														
Water flow rate	min. 1,000 l/h														
Min. operating pressure	10 kPa (0.1 bar)														
Max. operating pressure	300 kPa (3.0 bar)														
	<p><b>CAUTION!</b></p> <p>There is a risk of fire if the safety devices fail.</p> <p>If the electric heat exchanger overheats, this may cause a fire.</p> <p>The electric heat exchanger must be prevented from emptying during operation.</p> <p>Do not store flammable materials nearby.</p>														

### 2.3 Installation

Before installation, check the electric heat exchanger for any visible damage.

The electric heat exchanger can be installed horizontally or vertically above or below the water level.

When installed above or below 0.50 m of the water level, the safety pressure switch (low-water protection) loses its effectiveness.

In this case, a Behncke ® flow switch is absolutely necessary instead of the pressure switch.  
(see EWT 80-41/-71)

## 2.4 Water connection

### 2.4.1 Installation arrangement above the water level

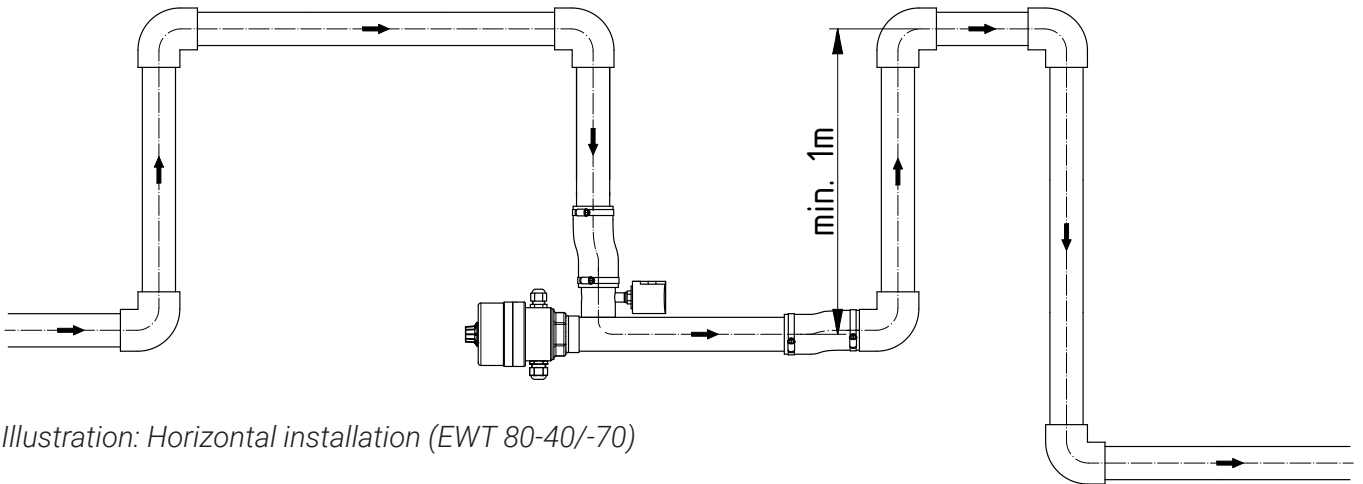

Illustration: Horizontal installation (EWT 80-40/-70)

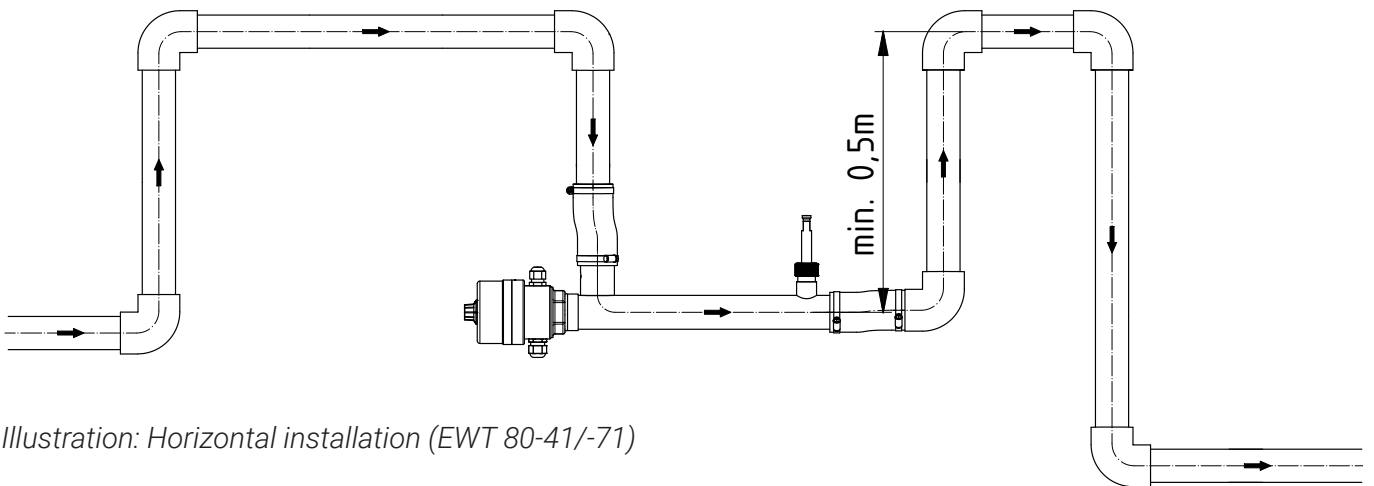

Illustration: Horizontal installation (EWT 80-41/-71)

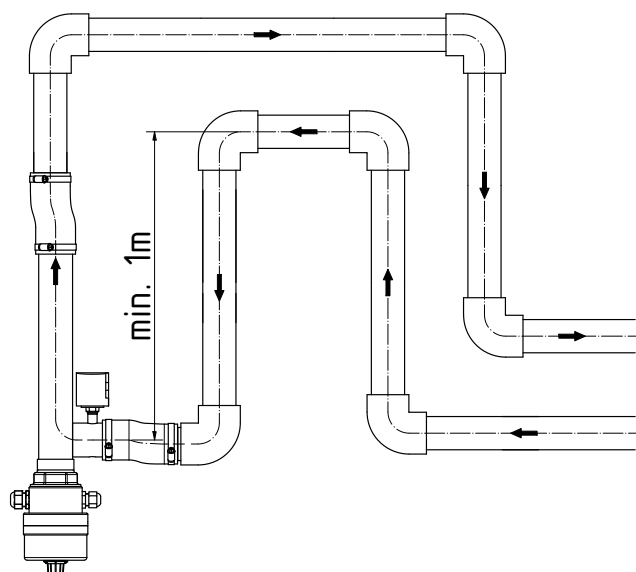

Illustration: Vertical installation (EWT 80-40/-70)

### 2.4.2 Installation arrangement below the water level

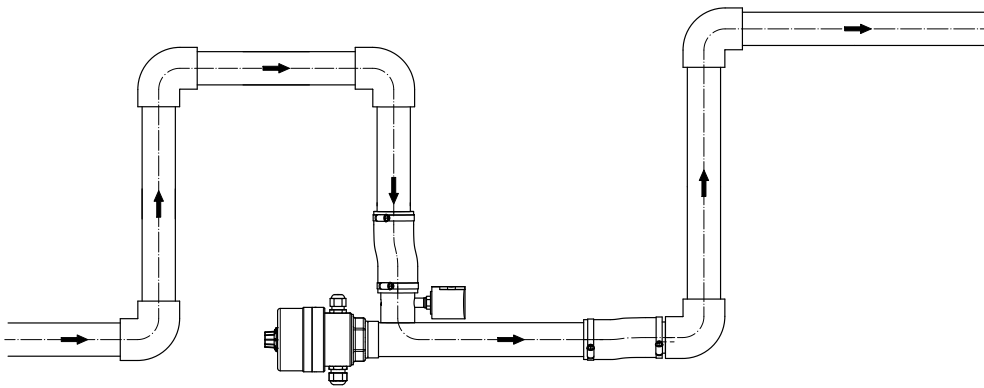

Illustration: Horizontal installation (EWT 80-40/-70)

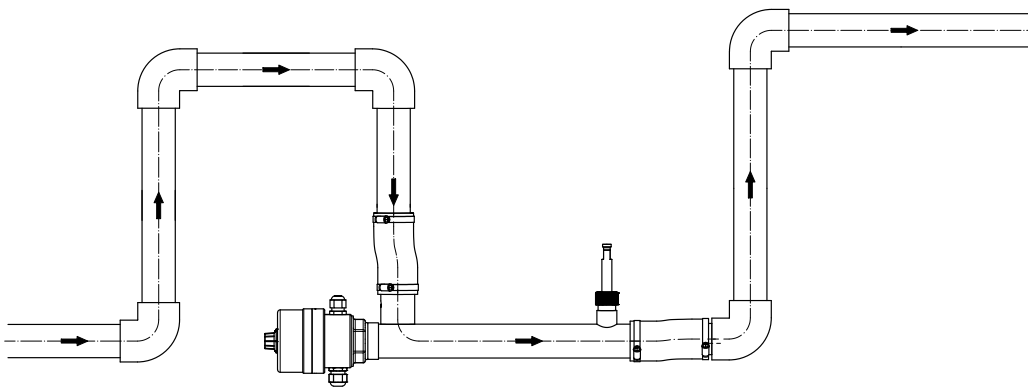

Illustration: Horizontal installation (EWT 80-41/-71)

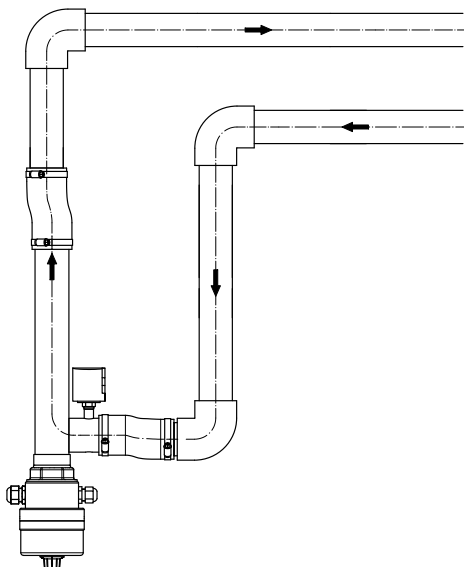



Illustration: Vertical installation (EWT 80-40/-70)

### 2.4.3 Connecting the electric heat exchanger to the water circuit of a filter system

Install the electric heat exchanger in the pressure line (to the pool) after the pump and filter.

The EWT 80-40/-41 is connected to the water circuit via the 1 1/2" internal thread or via hose connections with hose clamps.

The EWT 80-70/-71 is integrated into the water circuit with d50 PVC adhesive fittings.

	<p><b>CAUTION!</b></p> <p>The electric heat exchanger may be damaged.</p> <p>When connecting to the water circuit, ensure that no metal parts get into the electric heat exchanger.</p>
	<p><b>CAUTION!</b></p> <p><b>The electric heat exchanger may be damaged by chemicals.</b></p> <p>Generally, disinfection devices must be installed in the direction of the flow after the electric heat exchanger. The distance must be at least 1 m and the following sequence must be observed: first regulate the hardness, then add the chlorine.</p> <p>If chemicals (e.g. chlorine gas) are used, no gases may enter the electric heat exchanger during filter downtimes.</p>

### 2.4.4 General installation instructions for the flow switch

The flow-calming section must be at least 5 x DN upstream and downstream of the flow control switch.

**The flow control switch may only be installed in a horizontal pipe.**

You must consult the manufacturer for different installation systems.

The switches should only be installed vertically, max. deviation 45° (see *fig. 1*).

Ensure that no external magnetic fields in the immediate vicinity of the flow control switch can affect the operation of the unit (see *fig. 2*).

There is an arrow on the flow control switch. During installation, make sure that it runs parallel with the pipe axis and points in the direction of flow (see *fig. 3*).

The plastic cap nut G 3/4 must be tightened with a maximum torque of 8 Nm.



Abb. 1



Abb. 2



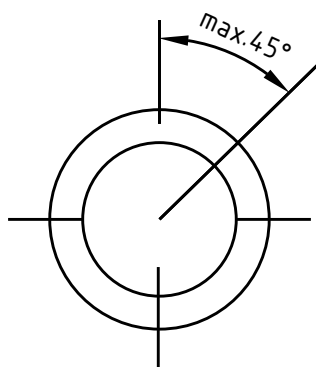



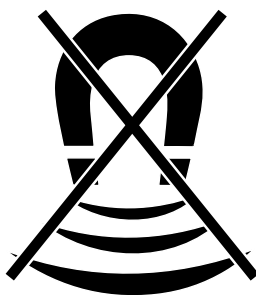

Abb. 3

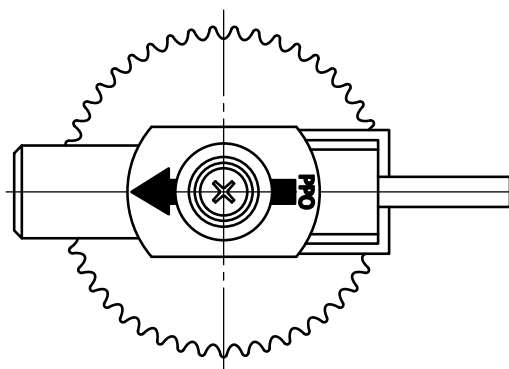
## 2.5 Electrical connection

	<p><b>ELECTRIC VOLTAGE!</b></p> <p>The electrical connection may only be made by an electrician. Local regulations and VDE 0100 must be taken into consideration when doing so. The heat exchanger must be permanently connected to permanently installed cables with a protective earth conductor.</p>
	<p><b>CAUTION!</b></p> <p><b>The electric heat exchanger must be protected by at least two safety switches.</b></p> <p>The following combinations are on offer ex works</p> <ul style="list-style-type: none"><li>– with a control thermostat</li><li>– with a control thermostat and a safety temperature limiter (STL)</li><li>– with a control thermostat, an STL and a flow switch.</li><li>– with a contactor up to 12 kW.</li></ul> <p>If no contactor is installed at the factory, an external contactor is required to switch the heating rod (e.g. Behncke control system for EWT 80-xx)</p>
	<p><b>NOTE!</b></p> <p>It must be ensured that the electric heat exchanger can only be switched on when the flow is ensured.</p> <p>The electrical connections are to be made according to the circuit diagram. For safety reasons, a ground fault circuit interrupter (30 mA) must be integrated into the power supply. All metal parts must be included in potential equalisation.</p>

## 2.6 Flow switch

	<p><b>CAUTION!</b></p> <p><b>Risk of death due to electric voltage!</b></p> <p>Disconnect the electrical system from the power supply before connecting the strands of the connecting cable.</p> <p>Brown/black = connections for the reed contact</p> <p>The reed contact is integrated in a plastic sleeve with protective insulation (protection class II).</p>
	<p><b>CAUTION!</b></p> <p><b>Risk of death due to electric voltage!</b></p> <p>The max. electrical contact load specified on the type plate must not be exceeded under any circumstances, as the reed contact integrated into the switching unit will be damaged otherwise. The switching capacity is reduced for inductive loads. Information on the protective circuit can be obtained from the manufacturer.</p>

### 3 Functional sequence

In the electric heat exchanger, heat is transferred to the pool water by the heating rod.

The thermostat regulates the water temperature to the set level, setting range: 0 to 40°C.

EWT 80-40/-70: If the required positive operating pressure drops below 6 kPa (0.06 bar) due to a lack of flow, the safety pressure limiter switches off the electric heat exchanger.

EWT 80-41/-71: If the required positive operating pressure drops below 36.0 l/min due to insufficient flow, the flow switch switches off the EWT.

Option: Safety thermostat

The safety temperature limiter protects against overheating. It switches off the electric heat exchanger at a temperature of 44°C.

By pressing the fault clear button, the electric heat exchanger can be restored to normal operational readiness after a fault has been rectified.

### 4 Start-up

Have you read and understood this instruction manual – particularly chapter 1, Safety? Do not activate the electric heat exchanger until you have!

- Set the desired pool water temperature on the thermostat.

The electric heat exchanger will heat the pool water until the set temperature has been reached.

	<p><b>CAUTION!</b></p> <p><b>The electric heat exchanger may be damaged.</b></p> <p>For safety reasons, work on the pipelines and the electrical installation may only be carried out by qualified personnel.</p> <p>Do not climb on the electric heat exchanger.</p> <p>Only carry out maintenance and cleaning work when the shut-off valves are closed in the water circuit!</p> <p>Deaerate the entire water circuit, otherwise the heating element may be damaged.</p>
---	---

### 5 Maintenance / servicing

Check the electric heat exchanger and the connections for leaks and bleed the entire water circuit weekly.

	<p><b>CAUTION!</b></p> <p><b>The electric heat exchanger may be damaged.</b></p> <p>For safety reasons, work on the electric heat exchanger may only be carried out by qualified personnel.</p> <p>Do not climb on the electric heat exchanger.</p> <p>Work on the pipe connections may only be carried out when the shut-off valves in the water circuit are closed!</p>
---	---

**5.1 Storing the electric heat exchanger over winter in frost-free rooms**

	<p><b>CAUTION!</b></p> <p>Procedures on technical systems by non-experts may lead to injuries and material damage.</p> <p>When shutting down in frost-free rooms, the electric heat exchanger must be completely filled with water or completely drained.</p>
---	---

**5.2 Storing the electric heat exchanger over winter in spaces at risk of frost**

	<p><b>CAUTION!</b></p> <p>It is possible to store the heat exchanger over winter without frost damage if the following steps are taken.</p> <ul style="list-style-type: none"> <li>• Close the shut-off valves in the water circuit. (Shut-off valves must be installed in frost-free rooms)</li> <li>• Rinse and drain the electric heat exchanger and the connecting pipework to the shut-off valves.</li> </ul>
---	--

**5.2.1 Electric heat exchanger in a vertical position**

Completely drain the electric heat exchanger via drain valves.

**5.2.2 Storing the electric heat exchanger over winter in a horizontal position**

Remove the electric heat exchanger in a horizontal position.

Rinse the electric heat exchanger to remove impurities and store in a dry place.

**6 Faults and corrections**

Fault	Investigate the possible causes
No output	<p>Is the electric heat exchanger connected to the mains? Are the shut-off valves in the water circuit open?</p> <p>Is the electric heat exchanger completely filled with water?</p> <p>Has the electric heat exchanger been bled?</p>
The electric heat exchanger continues to heat up even though the pool water circulation pump is switched off	<p>Is there sufficient water flow through the electric heat exchanger (see technical data)?</p> <p>Is the interlock between the pool water pump and the electric heat exchanger active?</p>

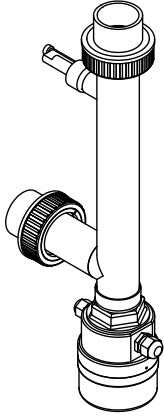

## MODE D'EMPLOI

**EWT-80-40/-41**

**EWT-80-70/-71**

**Échangeur de chaleur  
électrique**



**BEHNCKE GmbH**

**Bavière :**

Michael-Haslbeck Straße 13  
D-85640 Putzbrunn

Tél. : +49 (0)89 / 45 69 17-0  
Fax : +49 (0)89 / 45 69 17-61

**Saxe-Anhalt :**

Stötterlinger Straße 36 a  
D-38835 Bühne

Tél. : +49 (0)39421 / 796-0  
Fax : +49 (0)39421 / 796-30

**E-mail :** [info@behncke.com](mailto:info@behncke.com)  
**Site Internet :** [www.behncke.com](http://www.behncke.com)

**Sommaire**

<b>1</b>	<b>Sécurité</b>	<b>1</b>
1.1	Dangers lors de la manipulation de cet échangeur de chaleur électrique	1
1.2	Consignes de sécurité et conseils	1
1.3	Utilisation conforme	2
1.4	Sources de danger	3
1.5	Précautions à prendre sur le site d'installation	3
1.6	Dispositifs de sécurité	4
<b>2</b>	<b>Mise en place et installation</b>	<b>5</b>
2.1	Transport / stockage	5
2.2	Mise en place	5
2.3	Installation	5
2.4	Raccordement au réseau d'eau	6
2.4.1	<i>Installation au-dessus du niveau de l'eau</i>	6
2.4.2	<i>Installation au-dessous du niveau de l'eau</i>	7
2.4.3	<i>Raccordement de l'échangeur de chaleur électrique au circuit d'eau d'un système de filtration</i>	8
2.4.4	<i>Instructions générales de montage pour l'interrupteur de débit</i>	8
2.5	Raccordement électrique	9
2.6	Interrupteur de débit	9
<b>3</b>	<b>Fonctionnement</b>	<b>10</b>
<b>4</b>	<b>Mise en service</b>	<b>10</b>
<b>5</b>	<b>Maintenance / entretien</b>	<b>10</b>
5.1	Stockage de l'échangeur de chaleur à l'abri du gel en hiver	11
5.2	Stockage de l'échangeur de chaleur dans des locaux exposés à un risque de gel en hiver	11
5.2.1	<i>Échangeur de chaleur électrique en position verticale</i>	11
5.2.2	<i>Stockage de l'échangeur de chaleur en position horizontale en hiver</i>	11
<b>6</b>	<b>Défauts et remèdes</b>	<b>11</b>
<b>7</b>	<b>Illustrations techniques</b>	<b>Onglet : Illustrations techniques</b>
<b>8</b>	<b>Déclaration de conformité</b>	<b>Onglet : Illustrations techniques</b>

# 1 Sécurité

## 1.1 Dangers lors de la manipulation de cet échangeur de chaleur électrique

L'échangeur de chaleur électrique est fabriqué sur la base de l'état de la technique et des réglementations techniques reconnues en matière de sécurité. Néanmoins, des risques peuvent survenir lors de son utilisation, à savoir

- la blessure de l'utilisateur ou
- de tiers ou
- la détérioration de l'échangeur de chaleur électrique ou
- l'endommagement d'autres biens matériels.

Toutes les personnes chargées de l'installation, de la mise en service, de l'utilisation, de la maintenance et de l'entretien de l'échangeur de chaleur électrique, doivent

- disposer des qualifications nécessaires.
- strictement observer ces instructions d'installation.

Cet appareil n'est pas destiné à être utilisé par des personnes (y compris des enfants) dont les capacités physiques, sensorielles ou mentales sont réduites ou qui manquent d'expérience et/ou de connaissances, à moins qu'elles ne soient surveillées par une personne responsable de leur sécurité ou qu'elles n'aient reçu de la part de celle-ci des instructions sur la manière d'utiliser l'appareil.

Utilisez l'échangeur de chaleur électrique uniquement





- pour la finalité pour laquelle celui-ci a été conçu.
- dans un état technique intact, où la sécurité est garantie.

En cas d'incidents techniques susceptibles de nuire à la sécurité, veuillez faire appel à un électricien qualifié.

Il est recommandé d'installer un détecteur de fumée dans les locaux abritant des appareils électriques en cours de fonctionnement !

Il en va de votre sécurité.

## 1.2 Consignes de sécurité et conseils

Symbole	Mention d'avertissement / Signification
	<b>DANGER</b> Vous met en garde contre une situation dangereuse entraînant des blessures graves ou la mort si celle-ci n'est pas évitée.
	<b>AVERTISSEMENT</b> Vous met en garde contre une situation potentiellement dangereuse susceptible d'entraîner des blessures graves ou la mort si celle-ci n'est pas évitée.
	<b>PRUDENCE</b> Vous met en garde contre une situation dangereuse susceptible d'entraîner des blessures légères à moyennement graves si celle-ci n'est pas évitée.
	<b>REMARQUE</b> Attire votre attention sur le risque d'apparition de dommages matériels ou sur d'autres informations importantes.

Le non-respect de cette consigne peut entraîner le dysfonctionnement du système ou de son environnement.

### 1.3 Utilisation conforme

L'échangeur de chaleur électrique est destiné exclusivement à chauffer l'eau de bain lorsque la pompe de circulation ou la pompe de filtre est en marche.

Toute utilisation autre ou dépassant ce cadre est jugée non conforme. Le fabricant BEHNCKE® GmbH décline toute responsabilité en cas de dommages découlant d'une utilisation non conforme.

Toute autre utilisation n'est possible qu'après consultation du fabricant et sur l'accord de ce dernier.

	<p><b>REMARQUE !</b></p> <p>L'utilisation conforme couvre également :</p> <ul style="list-style-type: none"> <li>- la prise en compte de toutes les remarques indiquées au niveau des instructions de service, et</li> <li>- le respect du calendrier d'inspection et de maintenance</li> </ul> <p>La surpression de service maximale admissible de 300 kPa (3 bar) ne doit pas être dépassée.</p> <p>La surpression de service minimale requise de 10 kPa (0,1 bar) doit toujours être atteinte.</p> <p>Le débit minimal est de 1000 l/h.</p>
---	--

**Utilisez seulement une eau présentant les paramètres suivants :**

#### **EWT 80-40/-41, 80-70/-71**



Chlorure	max. 500 mg/l
Chlore libre	max. 1,3 mg/l
pH	6,8 - 8,2
Indice de Langelier	-0,3 – +0,3

**La résistivité de l'eau ne doit pas être inférieure à  $\leq 1100 \Omega \text{ cm}$  à 15 °C.**

Pour des raisons de sécurité, il est interdit d'apporter des transformations ou modifications à l'échangeur de chaleur électrique.

Pour des raisons de sécurité, toutes les opérations de maintenance et réparations apportées aux conduites et à l'installation électrique doivent être confiées uniquement à un personnel qualifié.



## 1.4 Sources de danger

	<p><b>PRUDENCE !</b></p> <p><b>L'échangeur de chaleur électrique peut être endommagé.</b></p> <p>En cas de dépassement de la surpression de service maximale de 300 kPa (3,0 bar), l'échangeur de chaleur électrique risque d'avoir des fuites.</p>
	<p><b>PRUDENCE !</b></p> <p><b>Risque de brûlure.</b></p> <p>Les connexions et l'échangeur de chaleur électrique peuvent atteindre des températures allant jusqu'à 100 °C.</p> <p>Si le débit d'eau est insuffisant (&lt; 1000 l/h), l'échangeur de chaleur électrique risque de surchauffer considérablement.</p> <p>L'installation d'un contrôleur de débit comme dispositif de sécurité supplémentaire est généralement recommandée.</p>
	<p><b>PRUDENCE !</b></p> <p><b>L'échangeur de chaleur électrique peut être endommagé.</b></p> <p>L'eau tombant goutte-à-goutte sur l'enveloppe extérieure ou la pénétration de particules métalliques dans l'échangeur de chaleur électrique entraîne un risque de corrosion par contact.</p>

## 1.5 Précautions à prendre sur le site d'installation

L'échangeur de chaleur électrique doit être installé dans un local à l'abri du gel avec un support en acier inoxydable ou en plastique.

Assurez-vous que la pression de service ne dépasse pas le niveau maximal de 300 kPa (3,0 bar).

	<p><b>PRUDENCE !</b></p> <p>L'échangeur de chaleur électrique ou l'environnement risque d'être dégradé.</p> <p>Pendant la saison de baignade, inspectez au moins une fois par semaine l'échangeur de chaleur électrique et ses connexions afin de détecter toute fuite ou tout dommage apparent.</p>
	<p><b>PRUDENCE !</b></p> <p><b>Risque d'incendie.</b></p> <p>Si le débit d'eau est insuffisant (&lt; 1000 l/h), l'échangeur de chaleur électrique risque de surchauffer considérablement.</p> <p>Ne stockez aucune substance combustible à proximité.</p> <p>L'installation d'un contrôleur de débit comme dispositif de sécurité supplémentaire est généralement recommandée.</p> <p>Il empêche également la résistance chauffante de fondre lorsque la circulation de l'eau est arrêtée.</p>

**PRUDENCE !****L'échangeur de chaleur électrique peut être endommagé.**

L'échangeur de chaleur électrique ne doit être mis en service qu'après s'être assuré que celui-ci sera constamment alimenté en eau pendant le fonctionnement. Le débit d'eau doit être d'au moins 1000 l/h.

**1.6 Dispositifs de sécurité**

La plaque d'avertissement située sur l'échangeur de chaleur électrique met en garde contre les risques d'électrocution.

L'échangeur de chaleur électrique est équipé d'un limiteur de pression.

Le limiteur de pression est une sécurité en cas de manque d'eau (voir EWT 80-40 ou -70).

**PRUDENCE !**

L'échangeur de chaleur électrique doit être protégé par au moins deux interrupteurs de sécurité.

Les combinaisons suivantes sont proposées en usine

- avec un limiteur de température
- avec un thermostat régulateur de température et un limiteur de température
- avec un thermostat régulateur de température, un limiteur de température et un interrupteur de débit
- avec un contacteur jusqu'à 12 kW.

Si aucun contacteur n'est installé en usine, un contacteur externe est nécessaire pour contrôler la tige chauffante (p. ex. le contrôleur Behncke ® pour EWT 80-xx).

Contrôleur avec un contacteur :	3-12 kW	N° art. 304 006 12
	15-18 kW	N° art. 304 006 18

Contrôleur avec un deuxième contacteur intégré pour la coupure de sécurité avec voyant témoin (vivement recommandé) pour EWT 80-41/-71 thermostat de sécurité et régulateur de température :

3-12 kW	N° art. 304 007 12
15-18 kW	N° art. 304 007 18

– Coffret électrique non fourni ! –

Les dispositifs de sécurité coupent l'échangeur de chaleur électrique dès que des niveaux inadmissibles sont atteints.

## 2 Mise en place et installation

### 2.1 Transport / stockage

Transportez l'échangeur de chaleur électrique seulement après l'avoir vidé.



Rangez l'échangeur de chaleur électrique lavé et vidé uniquement dans des locaux où règne une atmosphère non agressive.

### 2.2 Mise en place

N'installez l'échangeur de chaleur électrique que dans des locaux secs, à l'abri du gel où règne une atmosphère non agressive.

L'eau qui coule peut endommager l'échangeur de chaleur électrique.

L'appareil doit être facilement accessible en vue de son montage et de son démontage.

	<p><b>PRUDENCE !</b></p> <p>Les paramètres d'eau suivants doivent obligatoirement être respectés pour l'échangeur de chaleur électrique.</p> <p><b>EWT 80-40/-41, 80-70/-71</b></p> <table><tr><td>Chlorure</td><td>max. 500 mg/l</td></tr><tr><td>Chlore libre</td><td>max. 1,3 mg/l</td></tr><tr><td>pH</td><td>6,8 - 8,2</td></tr><tr><td>Indice de Langelier</td><td>-0,3 – +0,3</td></tr><tr><td>Débit d'eau</td><td>min. 1000 l/h</td></tr><tr><td>Pression de service min.</td><td>10 kPa (0,1 bar)</td></tr><tr><td>Pression de service max.</td><td>300 kPa (3,0 bar)</td></tr></table>	Chlorure	max. 500 mg/l	Chlore libre	max. 1,3 mg/l	pH	6,8 - 8,2	Indice de Langelier	-0,3 – +0,3	Débit d'eau	min. 1000 l/h	Pression de service min.	10 kPa (0,1 bar)	Pression de service max.	300 kPa (3,0 bar)
Chlorure	max. 500 mg/l														
Chlore libre	max. 1,3 mg/l														
pH	6,8 - 8,2														
Indice de Langelier	-0,3 – +0,3														
Débit d'eau	min. 1000 l/h														
Pression de service min.	10 kPa (0,1 bar)														
Pression de service max.	300 kPa (3,0 bar)														
	<p><b>PRUDENCE !</b></p> <p>Risque d'incendie en cas de panne des dispositifs de sécurité.</p> <p>La surchauffe de l'échangeur de chaleur électrique peut causer un incendie.</p> <p>Évitez que l'échangeur de chaleur électrique ne marche à vide quand il est en cours de fonctionnement.</p> <p>Ne stockez aucune substance combustible à proximité.</p>														

### 2.3 Installation

Avant l'installation, il convient de vérifier que l'échangeur de chaleur électrique ne présente aucun dommage apparent.

L'échangeur de chaleur électrique peut être installé à l'horizontale ou à la verticale au-dessus ou au-dessous du niveau de l'eau.

Si l'échangeur de chaleur électrique est installé 0,50 m au-dessus ou au-dessous du niveau de l'eau, le pressostat de sécurité (protection contre le manque d'eau) perd son efficacité.

Dans ce cas, le pressostat doit impérativement être remplacé par un interrupteur de débit Behncke ®. (voir EWT 80-41/-71)

## 2.4 Raccordement au réseau d'eau

### 2.4.1 Installation au-dessus du niveau de l'eau

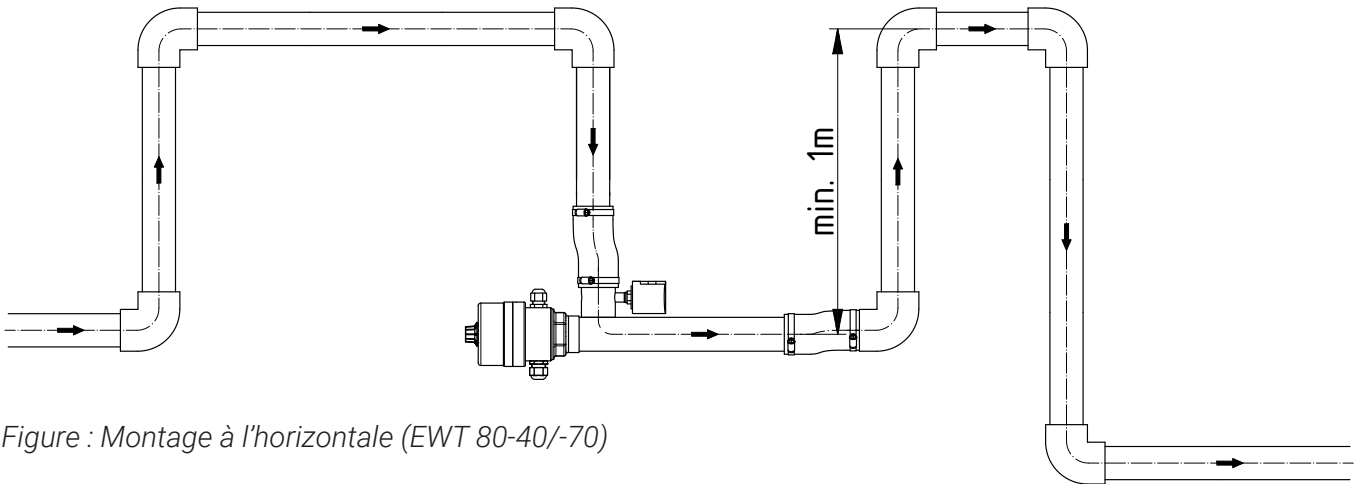

Figure : Montage à l'horizontale (EWT 80-40/-70)

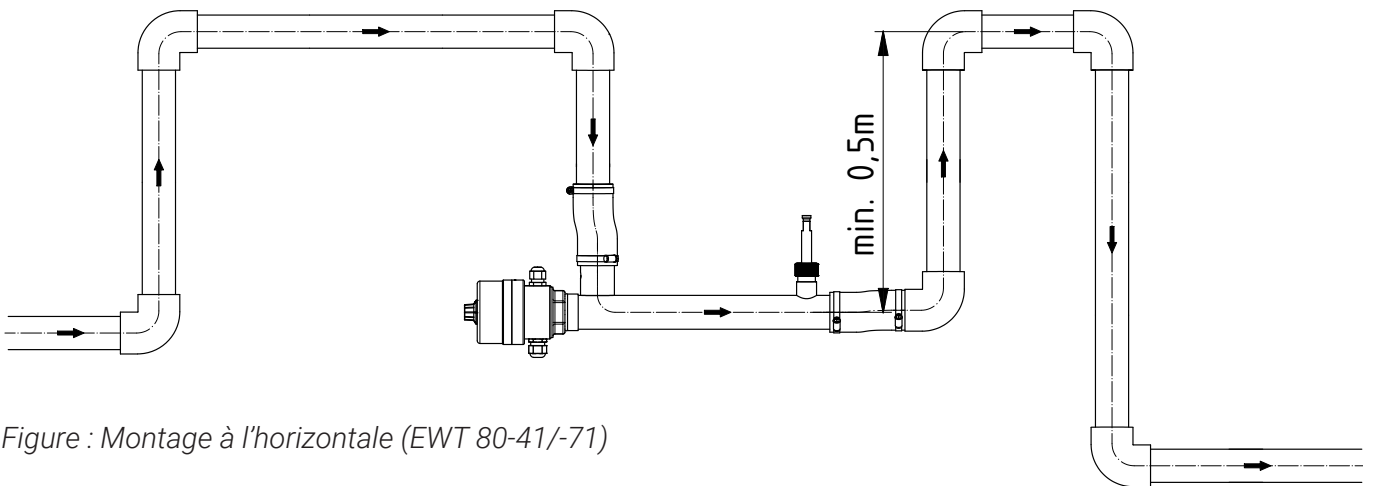

Figure : Montage à l'horizontale (EWT 80-41/-71)

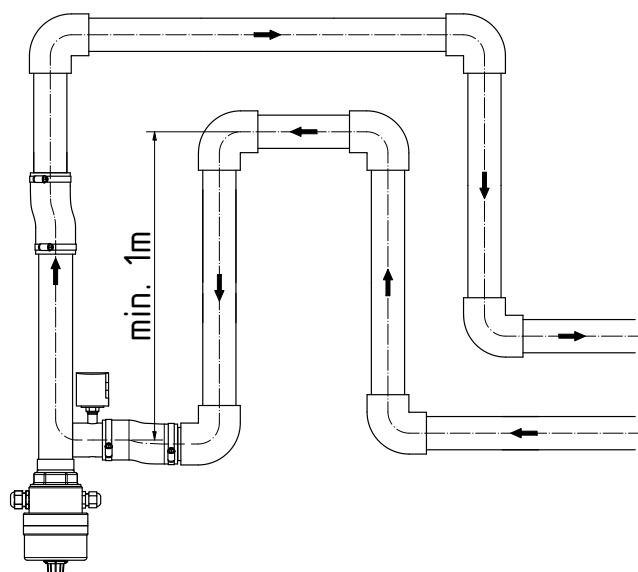

Figure : Montage à la verticale (EWT 80-40/-70)

### 2.4.2 Installation au-dessous du niveau de l'eau

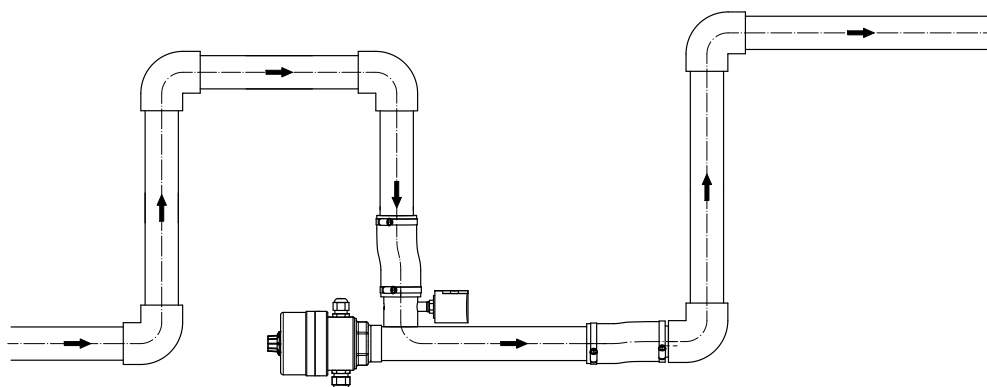

Figure : Montage à l'horizontale (EWT 80-40/-70)

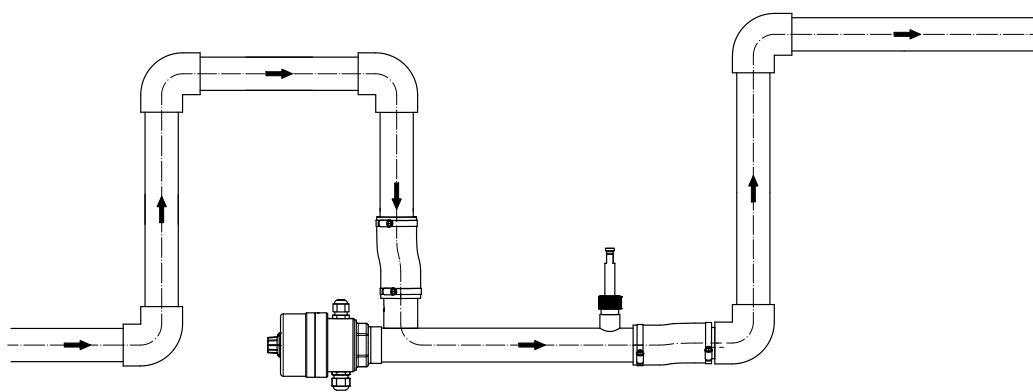

Figure : Montage à l'horizontale (EWT 80-41/-71)

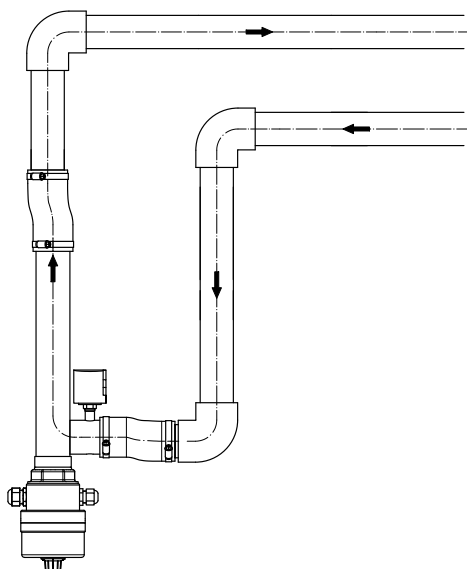



Figure : Montage à la verticale (EWT 80-40/-70)

### 2.4.3 Raccordement de l'échangeur de chaleur électrique au circuit d'eau d'un système de filtration

Installez l'échangeur de chaleur électrique dans la conduite de refoulement (en direction du bassin) en aval de la pompe et du filtre.

L'EWT 80-40/-41 est intégré dans le circuit d'eau à l'aide des filetages intérieurs 1 1/2" ou par des raccords de tuyaux avec des colliers de serrage.

L'EWT 80-70/-71 est intégré au circuit d'eau avec des raccords à visser adhésifs en PVC d50.

	<p><b>PRUDENCE !</b></p> <p>L'échangeur de chaleur électrique peut être endommagé.</p> <p>Lors du raccordement au circuit d'eau, veillez à ce qu'aucune particule métallique ne pénètre dans l'échangeur de chaleur électrique.</p>
	<p><b>PRUDENCE !</b></p> <p><b>L'échangeur de chaleur électrique peut être endommagé sous l'action de produits chimiques.</b></p> <p>Les dispositifs de désinfection doivent généralement être installés dans le sens d'écoulement après l'échangeur de chaleur électrique. Ils doivent se trouver à une distance d'au moins un mètre et être installés dans cet ordre : d'abord la régulation de la dureté puis l'injection de chlore.</p> <p>En cas d'utilisation de produits chimiques (par exemple, le chlore gazeux), aucun gaz ne doit pénétrer dans l'échangeur de chaleur électrique pendant les périodes d'inactivité des filtres.</p>

### 2.4.4 Instructions générales de montage pour l'interrupteur de débit

La distance de stabilisation doit être au minimum 5 x DN en amont et en aval de l'interrupteur de débit.

L'interrupteur de débit ne peut être installé que dans une conduite horizontale.

En cas de systèmes de pose différents, nous vous prions de consulter le fabricant.

Les interrupteurs ne doivent être montés que verticalement, avec un écart max. de 45° (voir la Fig. 1).

Assurez-vous qu'aucun champ magnétique externe ne peut perturber le fonctionnement de l'appareil dans l'environnement immédiat de l'interrupteur de débit (voir la Fig. 2).

Une flèche se trouve sur l'interrupteur de débit. Lors du montage, veillez à ce que celui-ci soit tout à fait parallèle à l'axe de la conduite et orienté dans le sens d'écoulement (voir la Fig. 3).

Vous devez serrer l'écrou-raccord G 3/4 en plastique avec un couple maximal de 8 Nm.



Abb. 1



Abb. 2



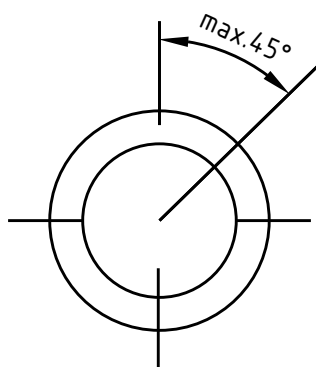



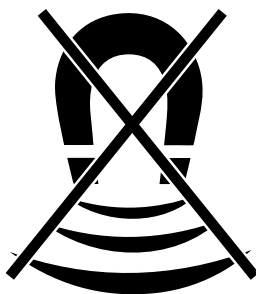

Abb. 3

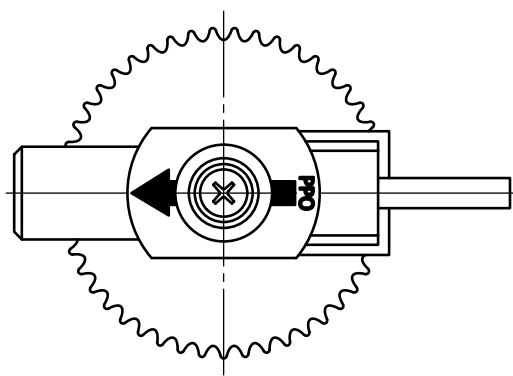
## 2.5 Raccordement électrique

	<p><b>TENSION ÉLECTRIQUE !</b></p> <p>La connexion électrique doit être réalisée uniquement par un électricien professionnel. Il convient alors d'observer les réglementations locales ainsi que la norme VDE 0100. L'échangeur de chaleur doit être relié de manière permanente à des câbles fixes, dotés d'un conducteur de protection.</p>
	<p><b>PRUDENCE !</b></p> <p><b>L'échangeur de chaleur électrique doit être protégé par au moins deux interrupteurs de sécurité.</b></p> <p>Les combinaisons suivantes sont proposées en usine</p> <ul style="list-style-type: none"><li>– avec un thermostat régulateur de température</li><li>– avec un thermostat régulateur de température et un limiteur de température</li><li>– avec un thermostat régulateur de température, un limiteur de température et un interrupteur de débit</li><li>– avec un contacteur jusqu'à 12 kW.</li></ul> <p>Si aucun contacteur n'est installé en usine, un contacteur externe est nécessaire pour contrôler la tige chauffante (p. ex. le contrôleur Behncke pour EWT 80-xx).</p>
	<p><b>REMARQUE !</b></p> <p>Assurez-vous que l'échangeur de chaleur électrique ne peut être mis en marche que lorsque le débit est assuré.</p> <p>Les connexions électriques doivent être effectuées conformément au schéma électrique.</p> <p>Installez un disjoncteur différentiel (30 mA) dans l'alimentation électrique pour des raisons de sécurité. Toutes les pièces métalliques doivent être intégrées dans la liaison équipotentielle.</p>

## 2.6 Interrupteur de débit

	<p><b>PRUDENCE !</b></p> <p><b>Danger de mort lié à la tension électrique !</b></p> <p>Mettez l'installation électrique hors tension avant de raccorder les fils du câble de connexion.</p> <p>marron / noir = connexions pour le contact Reed</p> <p>Le contact Reed est isolé (classe de protection II) et intégré dans un manchon en plastique.</p>
	<p><b>PRUDENCE !</b></p> <p><b>Danger de mort lié à la tension électrique !</b></p> <p>La charge maximale du contact électrique indiquée sur la plaque signalétique ne doit en aucun cas être dépassée, auquel cas le contact Reed intégré dans l'unité de commutation risque d'être endommagé. En présence de charges inductives, la capacité de coupure diminue. Pour obtenir des informations sur le circuit de protection, contactez le fabricant.</p>

### 3 Fonctionnement

Dans l'échangeur de chaleur électrique, la chaleur est transférée à l'eau du bain par la tige chauffante.

Le thermostat régule la température de l'eau au niveau défini, dans une plage de réglage de : 0 à 40 °C.

EWT 80-40/-70 : Si la surpression de service requise descend en dessous de 6 kPa (0,06 bar) en raison d'un débit insuffisant, le limiteur de pression arrête l'échangeur de chaleur électrique.

EWT 80-41/-71 : Si la surpression de service requise descend en dessous de 36,0 l/min en raison d'un débit insuffisant, l'interrupteur de débit arrête l'EWT.

Option : Thermostat de sécurité

Le limiteur de température empêche toute surchauffe. Il désactive l'échangeur de chaleur électrique dès que celui-ci atteint une température de 44 °C.

Appuyez sur le bouton de réarmement pour remettre l'échangeur de chaleur électrique en mode de fonctionnement normal après avoir réparé un défaut.

### 4 Mise en service

Avez-vous lu et compris le présent mode d'emploi, en particulier le chapitre 1 « Sécurité » ? Vous ne devez pas mettre l'échangeur de chaleur électrique en service avant d'avoir entrepris cette étape !

- Réglez la température souhaitée de l'eau du bain sur le thermostat.

Tant que la température de consigne n'est pas atteinte, l'échangeur de chaleur électrique chauffe l'eau du bain.

	<p><b>PRUDENCE !</b></p> <p><b>L'échangeur de chaleur électrique peut être endommagé.</b></p> <p>Pour des raisons de sécurité, les opérations sur les conduites et l'installation électrique doivent être confiées uniquement à un personnel qualifié.</p> <p>Ne montez pas sur l'échangeur de chaleur électrique.</p> <p>Avant d'entreprendre des travaux de maintenance et de nettoyage, veillez impérativement à ce que les dispositifs de coupure dans le circuit d'eau soient bien fermés !</p> <p>Purgez tout le circuit d'eau pour éviter que l'élément chauffant ne soit endommagé.</p>
---	---

### 5 Maintenance / entretien

Vérifiez chaque semaine l'étanchéité de l'échangeur électrique et des connexions et purgez tout le circuit d'eau.

	<p><b>PRUDENCE !</b></p> <p><b>L'échangeur de chaleur électrique peut être endommagé.</b></p> <p>Pour des raisons de sécurité, les opérations sur l'échangeur de chaleur électrique doivent être confiées uniquement à un personnel qualifié.</p> <p>Ne montez pas sur l'échangeur de chaleur électrique.</p> <p>Les opérations sur les raccords de conduite ne doivent être effectuées que lorsque les dispositifs de coupure dans les circuits d'eau sont fermés !</p>
---	--

## 5.1 Stockage de l'échangeur de chaleur à l'abri du gel en hiver

	<p><b>PRUDENCE !</b></p> <p>Toute intervention entreprise sur des équipements techniques par des personnes non initiées implique un risque de blessures et de dommages matériels.</p> <p>Lorsque l'échangeur de chaleur électrique est à l'arrêt et stocké dans un lieu à l'abri du gel, il doit être rempli d'eau ou entièrement vide.</p>
---	---

## 5.2 Stockage de l'échangeur de chaleur dans des locaux exposés à un risque de gel en hiver

	<p><b>PRUDENCE !</b></p> <p>L'échangeur de chaleur peut être stocké en hiver sans subir de dommages dus au gel à condition d'exécuter les étapes suivantes.</p> <ul style="list-style-type: none"> <li>• Fermeture des dispositifs de coupure dans le circuit d'eau. (Les dispositifs de coupure doivent être installés dans des locaux à l'abri du gel.)</li> <li>• Rinçage et vidange de l'échangeur de chaleur électrique puis des conduites jusqu'aux dispositifs de coupure.</li> </ul>
---	--

### 5.2.1 Échangeur de chaleur électrique en position verticale

Vider entièrement l'échangeur de chaleur électrique à l'aide des robinets de vidange.

### 5.2.2 Stockage de l'échangeur de chaleur en position horizontale en hiver

Démontez l'échangeur de chaleur électrique en position horizontale.

Rincez l'échangeur de chaleur électrique pour éliminer les impuretés puis rangez-le au sec.

## 6 Défaits et remèdes

Incident	Examen de la cause possible
Pas de puissance	<p>L'échangeur de chaleur électrique est-il raccordé au réseau de courant ? Les dispositifs de coupure dans le circuit d'eau sont-ils ouverts ?</p> <p>L'échangeur de chaleur électrique est-il complètement rempli d'eau ?</p> <p>L'échangeur de chaleur électrique a-t-il été purgé ?</p>
L'échangeur de chaleur électrique continue d'être chauffé même lorsque la pompe de circulation pour l'eau du bain est désactivée	<p>Le débit d'eau dans l'échangeur de chaleur électrique est-il suffisant (voir les Caractéristiques techniques) ?</p> <p>Le système de verrouillage entre la pompe pour l'eau du bain et l'échangeur de chaleur électrique est-il actif ?</p>

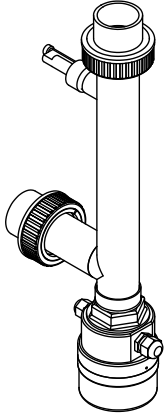

## ISTRUZIONI PER L'USO

**EWT-80-40/-41**

**EWT-80-70/-71**

**Scambiatore di calore  
elettrico**



**BEHNCKE GmbH**

**Baviera:**

Michael-Haslbeck Straße 13  
D-85640 Putzbrunn

Telefono: +49 (0)89 / 45 69 17-0

Fax: +49 (0)89 / 45 69 17-61

**Sassonia-Anhalt:**

Stötterlinger Straße 36 a  
D-38835 Bühne

Telefono: +49 (0)39421 / 796-0

Fax: +49 (0)39421 / 796-30

**E-mail:** [info@behncke.com](mailto:info@behncke.com)

**Internet:** [www.behncke.com](http://www.behncke.com)

**Indice**

<b>1</b>	<b>Sicurezza</b>	<b>1</b>
1.1	Pericoli nell'utilizzo dello scambiatore di calore elettrico	1
1.2	Istruzioni e consigli per la sicurezza	1
1.3	Uso conforme	2
1.4	Fonti di pericolo	3
1.5	Misure di sicurezza nel luogo di installazione	3
1.6	Dispositivi di sicurezza	4
<b>2</b>	<b>Montaggio e installazione</b>	<b>5</b>
2.1	Trasporto/stoccaggio	5
2.2	Montaggio	5
2.3	Installazione	5
2.4	Allaccio all'acqua	6
2.4.1	<i>Disposizione dell'installazione sopra il livello dell'acqua</i>	6
2.4.2	<i>Disposizione di installazione sotto il livello dell'acqua</i>	7
2.4.3	<i>Allaccio dello scambiatore di calore elettrico al circuito dell'acqua di un impianto di filtrazione</i>	8
2.4.4	<i>Indicazioni generali per il montaggio relative al sensore di flusso</i>	8
2.5	Collegamento elettrico	9
2.6	Sensore di flusso	9
<b>3</b>	<b>Procedura</b>	<b>10</b>
<b>4</b>	<b>Messa in funzione</b>	<b>10</b>
<b>5</b>	<b>Manutenzione ordinaria / straordinaria</b>	<b>10</b>
5.1	Svernare l'EWT nelle stanze senza gelo	11
5.2	Svernare l'EWT nelle stanze a rischio di gelo	11
5.2.1	<i>Scambiatore di calore elettrico in posizione verticale</i>	11
5.2.2	<i>Svernare l'EWT in posizione orizzontale</i>	11
<b>6</b>	<b>Guasti e risoluzione</b>	<b>11</b>
<b>7</b>	<b>Scheda</b>	<b>illustrazioni tecniche: Illustrazioni tecniche</b>
<b>8</b>	<b>Scheda</b>	<b>dichiarazione di conformità: Illustrazioni tecniche</b>

## 1 Sicurezza

### 1.1 Pericoli nell'utilizzo dello scambiatore di calore elettrico

Lo scambiatore di calore elettrico è stato costruito secondo lo stato dell'arte della tecnica e le regole di sicurezza riconosciute. Ciononostante, durante il suo utilizzo possono sorgere dei pericoli, vale a dire

- Lesione dell'operatore o terzi o
- disturbi nello scambiatore di calore elettrico o
- danneggiamento di altri beni materiali.

Tutte le persone coinvolte nell'installazione, nella messa in funzione, nell'uso, nella manutenzione e nella pulizia dello scambiatore di calore devono rispondere ai seguenti requisiti:

- essere adeguatamente qualificati;
- osservare accuratamente le presenti istruzioni per l'installazione.

Questo dispositivo non è predisposto per essere utilizzato da persone (bambini compresi) con capacità fisiche, sensoriali o mentali limitate o con esperienza e/o competenze carenti, a meno che non vengano monitorati per la loro sicurezza da una persona competente o abbiano ricevuto istruzioni relative all'uso del dispositivo.

Lo scambiatore di calore elettrico deve essere usato solo





- per uso conforme.
- con perfette condizioni di sicurezza.

in caso di guasti che possono compromettere la sicurezza, rivolgersi sempre ad un elettricista.

Negli ambienti in cui sono in funzione dispositivi elettrici, si raccomanda di installare un rilevatore di fumo!

È in gioco la vostra sicurezza.

### 1.2 Istruzioni e consigli per la sicurezza

Simbolo	Parola chiave / Significato
	<b>PERICOLO</b> Segnala una situazione pericolosa che, se non evitata, comporta gravi lesioni o morte.
	<b>AVVERTENZA</b> Segnala una situazione potenzialmente pericolosa che, se non evitata, può causare morte o gravi lesioni.
	<b>ATTENZIONE</b> Segnala una situazione pericolosa che, se non evitata, comporta lesioni da lievi a medio gravi.
	<b>AVVERTENZA</b> Segnala possibili danni materiali e altre informazioni importanti.

L'inosservanza di questa avvertenza può causare disturbi all'impianto o nell'ambiente circostante.

### 1.3 Uso conforme

Lo scambiatore di calore elettrico è predisposto esclusivamente al riscaldamento dell'acqua di balneazione quando la pompa di circolazione o la pompa di filtraggio sono azionati.

Un uso diverso o eccedente tali indicazioni è da intendersi come non conforme. Il produttore BEHNCKE® GmbH non risponde per danni da ciò derivanti.

Un uso diverso è consentito soltanto se concordato e autorizzato dal produttore.

	<p><b>AVVERTENZA!</b></p> <p>L'uso conforme comprende anche</p> <ul style="list-style-type: none"> <li>- il rispetto di tutte le indicazioni delle istruzioni per l'installazione e</li> <li>- l'adempimento di tutte le operazioni di ispezione e manutenzione</li> </ul> <p>La pressione di esercizio massima ammessa di 300 kPa (3 bar) non deve essere superata.</p> <p>La pressione d'esercizio non deve essere inferiore a quella minima richiesta di 10 kPa (0,1 bar).</p> <p>La portata minima è di 1000 l/h.</p>
---	---

**Utilizzare esclusivamente l'acqua con i seguenti valori:**

#### **EWT 80-40/-41, 80-70/-71**



Contenuto di cloruro	max. 500 mg/l
cloro libero	max. 1,3 mg/l
pH	6,8 - 8,2
Indice di Langelier	-0,3 – +0,3

**La resistenza specifica dell'acqua non deve essere inferiore a  $\leq 1100 \Omega \text{ cm}$  a 15°C.**

Per motivi di sicurezza è vietato apportare trasformazioni e modifiche allo scambiatore di calore elettrico.

Per motivi di sicurezza, le operazioni di manutenzione e riparazione ai tubi e alle installazioni elettriche devono essere eseguite da tecnici specializzati.



## 1.4 Fonti di pericolo

	<p><b>ATTENZIONE!</b></p> <p><b>Lo scambiatore di calore elettrico può essere danneggiato.</b></p> <p>Se si supera la pressione massima di esercizio di 300 kPa (3,0 bar), lo scambiatore di calore elettrico può avere delle perdite.</p>
	<p><b>ATTENZIONE!</b></p> <p><b>Sussiste il pericolo di ustione.</b></p> <p>I raccordi e lo scambiatore di calore elettrico possono raggiungere temperature fino a 100°C.</p> <p>Se il flusso d'acqua è insufficiente (&lt; 1000 l/h), lo scambiatore di calore elettrico può surriscaldarsi notevolmente.</p> <p>L'installazione di un monitor di flusso come ulteriore dispositivo di sicurezza è generalmente raccomandata.</p>
	<p><b>ATTENZIONE!</b></p> <p><b>Lo scambiatore di calore elettrico può essere danneggiato.</b></p> <p>C'è il rischio di corrosione da contatto a causa del gocciolamento dell'acqua sul rivestimento esterno o se le parti metalliche nello scambiatore di calore elettrico vengono bagnate.</p>

## 1.5 Misure di sicurezza nel luogo di installazione

Lo scambiatore di calore elettrico deve essere installato in un locale protetto dal gelo con un supporto in acciaio inossidabile o in plastica.

Assicurarsi che la pressione di esercizio massima pari a 300 kPa (3,0 bar) non venga superata.

	<p><b>ATTENZIONE!</b></p> <p>Lo scambiatore di calore elettrico o l'ambiente possono subire danni.</p> <p>Durante la balneazione, controllare almeno una volta alla settimana lo scambiatore di calore elettrico e i suoi collegamenti per individuare eventuali perdite e danni visibili esternamente.</p>
	<p><b>ATTENZIONE!</b></p> <p><b>Sussiste il rischio di incendio.</b></p> <p>Se il flusso d'acqua è insufficiente (&lt; 1000 l/h), lo scambiatore di calore elettrico può surriscaldarsi notevolmente.</p> <p>Non conservare materiali infiammabili nelle vicinanze.</p> <p>L'installazione di un monitor di flusso come ulteriore dispositivo di sicurezza è generalmente raccomandata.</p> <p>Evita anche che il resistore di riscaldamento si bruci quando l'acqua si ferma.</p>

**ATTENZIONE!****Lo scambiatore di calore elettrico può essere danneggiato.**

Lo scambiatore di calore elettrico può essere messo in funzione soltanto se è stato garantito che durante il funzionamento, lo scambiatore di calore elettrico venga continuamente approvvigionato con acqua. La portata dell'acqua deve essere di almeno 1000 l/h.

**1.6 Dispositivi di sicurezza**

Il cartello di avvertenza sullo scambiatore di calore elettrico illustra i rischi derivanti da corrente elettrica.

Lo scambiatore di calore elettrico è dotato di un limitatore di pressione di sicurezza.

Il limitatore di pressione di sicurezza funge da protezione contro il funzionamento a secco (vedi 80-40 o -70).

**ATTENZIONE!**

Lo scambiatore di calore elettrico deve essere protetto da almeno due interruttori di sicurezza.

Le seguenti combinazioni sono offerte franco fabbrica

- con un limitatore di temperatura di sicurezza
- con un termostato di controllo e un limitatore di temperatura di sicurezza (LTS)
- con un termostato di controllo, un LTS e un sensore di flusso
- con un contattore fino a 12 kW.

Se non è installato alcun contattore di fabbrica, è necessario un contattore esterno per azionare il riscaldatore a immersione (per es. Sistema di comando Behncke ® per EWT 80-xx).

Sistema di comando con un contattore:	3–12 kW	Cod. art. 304 006 12
	15–18 kW	Cod. art. 304 006 18

Sistema di comando con secondo contattore integrato per lo spegnimento di sicurezza con spia luminosa di controllo (caldamente raccomandata) per EWT 80-41/-71 con regolatore e termostato di sicurezza:

	3–12 kW	Cod. art. 304 007 12
	15–18 kW	Cod. art. 304 007 18

– Quadro elettrico non compreso nell'oggetto di fornitura! –

I dispositivi di sicurezza spengono lo scambiatore di calore elettrico quando si raggiungono valori inammissibili.

## 2 Montaggio e installazione

### 2.1 Trasporto/stoccaggio

Trasportare lo scambiatore di calore elettrico solo quando è vuoto.



Conservare lo scambiatore di calore elettrico risciacquato e drenato solo al chiuso in un'atmosfera non aggressiva.

### 2.2 Montaggio

Installare lo scambiatore di calore elettrico solo in locali asciutti e al riparo dal gelo, con un'atmosfera non aggressiva.

L'acqua che gocciola può danneggiare lo scambiatore di calore elettrico.

Assicurare una facile accessibilità per il montaggio e lo smontaggio.

	<p><b>ATTENZIONE!</b></p> <p>I seguenti valori dell'acqua devono essere rispettati per lo scambiatore di calore elettrico.</p> <p><b>EWT 80-40/ -41, 80-70/-71</b></p> <table><tbody><tr><td>Contenuto di cloruro</td><td>max. 500 mg/l</td></tr><tr><td>cloro libero</td><td>max. 1,3 mg/l</td></tr><tr><td>pH</td><td>6,8 - 8,2</td></tr><tr><td>Indice di Langelier</td><td>-0,3 – +0,3</td></tr><tr><td>Portata dell'acqua</td><td>min. 1000 l/h</td></tr><tr><td>Pressione di esercizio min.</td><td>10 kPa (0,1 bar)</td></tr><tr><td>Pressione di esercizio max.</td><td>300 kPa (3,0 bar)</td></tr></tbody></table>	Contenuto di cloruro	max. 500 mg/l	cloro libero	max. 1,3 mg/l	pH	6,8 - 8,2	Indice di Langelier	-0,3 – +0,3	Portata dell'acqua	min. 1000 l/h	Pressione di esercizio min.	10 kPa (0,1 bar)	Pressione di esercizio max.	300 kPa (3,0 bar)
Contenuto di cloruro	max. 500 mg/l														
cloro libero	max. 1,3 mg/l														
pH	6,8 - 8,2														
Indice di Langelier	-0,3 – +0,3														
Portata dell'acqua	min. 1000 l/h														
Pressione di esercizio min.	10 kPa (0,1 bar)														
Pressione di esercizio max.	300 kPa (3,0 bar)														
	<p><b>ATTENZIONE!</b></p> <p>In caso di guasto dei dispositivi di sicurezza sussiste il rischio di incendio.</p> <p>Il surriscaldamento dello scambiatore di calore elettrico può comportare un incendio.</p> <p>Evitare un funzionamento a vuoto dello scambiatore di calore elettrico in esercizio.</p> <p>Non conservare materiali infiammabili nelle vicinanze.</p>														

### 2.3 Installazione

Prima dell'installazione, controllare che non ci siano danni visibili allo scambiatore di calore elettrico.

Lo scambiatore di calore elettrico può essere installato orizzontalmente o verticalmente sopra o sotto il livello dell'acqua.

Durante l'installazione al di sopra o al di sotto di 0,50 m del livello dell'acqua, il pressostato di sicurezza (protezione contro il funzionamento a secco) perde efficacia.

In questo caso, anziché il pressostato è assolutamente necessario un sensore di flusso Behncke ®. (vedi EWT 80-41/-71)

## 2.4 Allaccio all'acqua

### 2.4.1 Disposizione dell'installazione sopra il livello dell'acqua



Figura: Montaggio orizzontale (EWT 80-40/-70)



Figura: Montaggio orizzontale (EWT 80-41/-71)

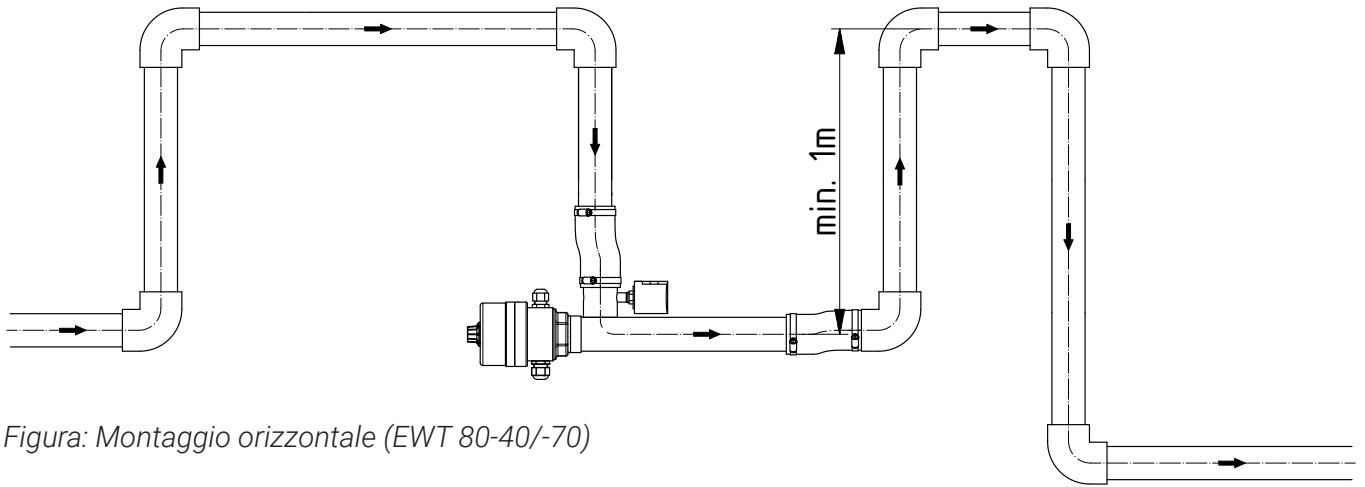

Figura: Montaggio verticale (EWT 80-40/-70)

## 2.4.2 Disposizione di installazione sotto il livello dell'acqua

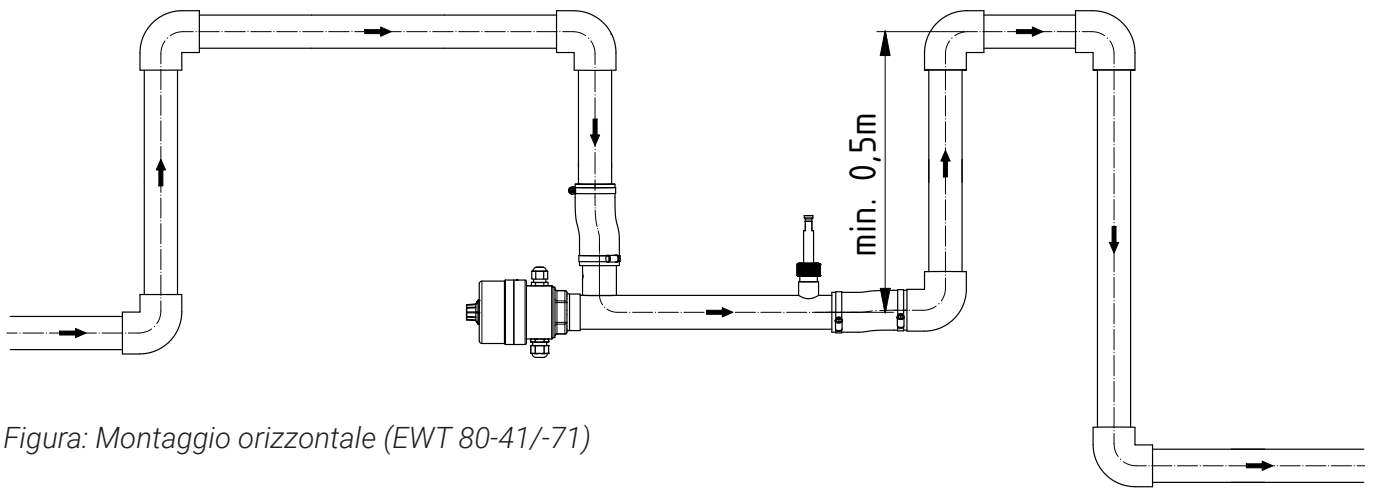

Figura: Montaggio orizzontale (EWT 80-40/-70)

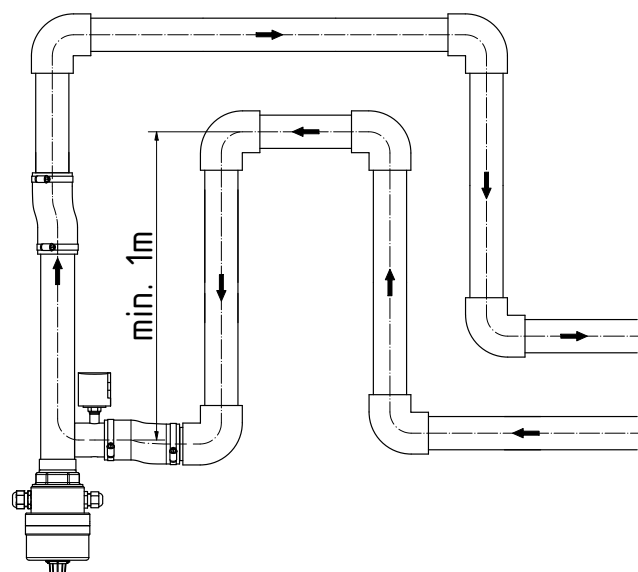

Figura: Montaggio orizzontale (EWT 80-41/-71)



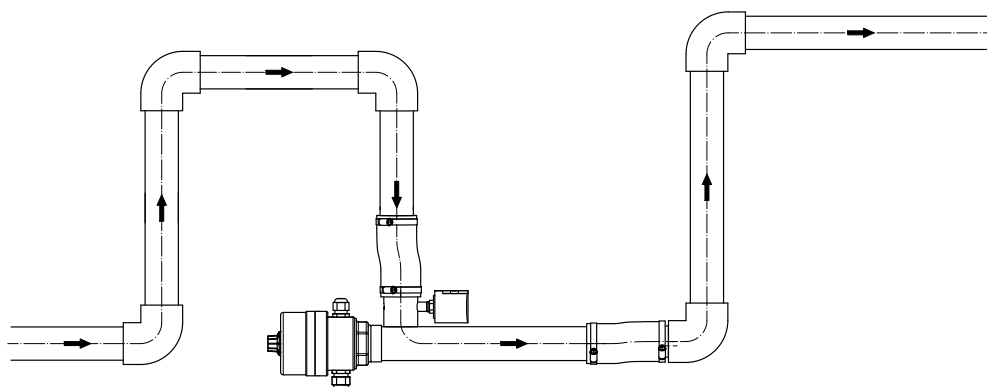

Figura: Montaggio verticale (EWT 80-40/-70)

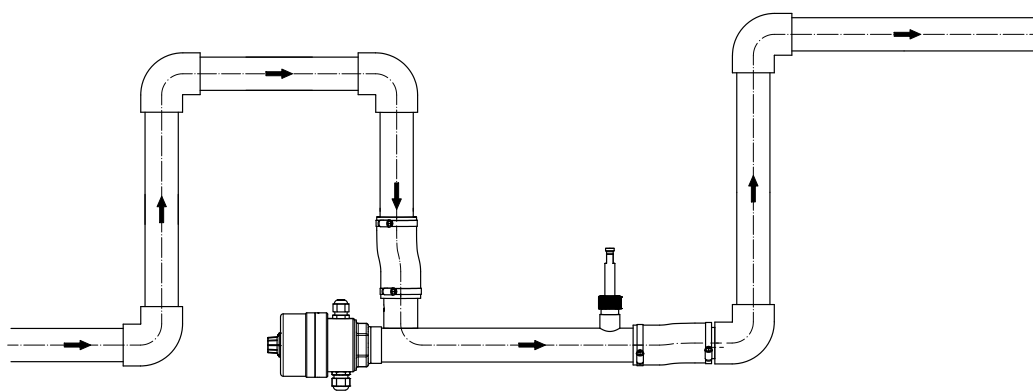
### 2.4.3 Allaccio dello scambiatore di calore elettrico al circuito dell'acqua di un impianto di filtrazione

Installare lo scambiatore di calore elettrico nella linea di pressione (verso la piscina) dopo la pompa e il filtro.

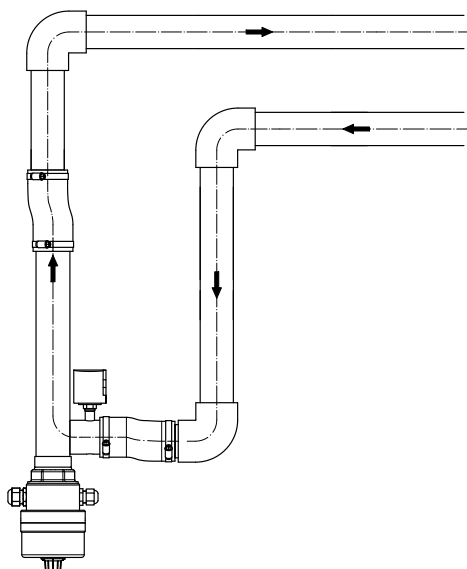
Lo EWT 80-40/-41 viene integrato nel circuito dell'acqua attraverso la filettatura interna 1 1/2" o attraverso i collegamenti per tubi flessibili con fascette stringitubo.

Lo EWT 80-70/-71 è integrato nel circuito dell'acqua con raccordi a vite adesivi d50 in PVC.

	<p><b>ATTENZIONE!</b></p> <p>Lo scambiatore di calore elettrico può essere danneggiato.</p> <p>Quando si collega al circuito d'acqua, assicurarsi che non vengano introdotte parti metalliche nello scambiatore di calore elettrico.</p>
	<p><b>ATTENZIONE!</b></p> <p><b>Lo scambiatore di calore elettrico può essere danneggiato dai prodotti chimici.</b></p> <p>Le unità di disinfezione devono essere sempre installate in direzione del flusso a valle dello scambiatore di calore elettrico. La distanza deve essere di almeno 1 m e deve essere rispettata la sequenza: prima la regolazione della durezza, poi l'inoculazione del cloro.</p> <p>Se si usano prodotti chimici (per esempio gas di cloro), nessun gas deve entrare nello scambiatore di calore elettrico durante i periodi di fermo del filtro.</p>

### 2.4.4 Indicazioni generali per il montaggio relative al sensore di flusso

La sezione di rallentamento deve essere pari davanti e dietro al sensore di controllo del flusso ad almeno 5 x DN.

**Il sensore di controllo del flusso deve essere montato esclusivamente in una linea orizzontale.**

In caso di impianti di montaggio divergenti, rivolgersi al produttore.

I sensori devono essere montati soltanto in posizione verticale, scostamento max. 45° (vedi Fig. 1).

Assicurarsi che nell'ambiente circostante del sensore di controllo della corrente non vi siano campi magnetici esterni che possano pregiudicare il funzionamento del dispositivo (vedi Fig. 2).

Sul sensore di controllo del flusso è presente una freccia. Durante il montaggio, fare attenzione che questo sia assolutamente parallelo all'asse del tubo e che indichi nella direzione del flusso (vedi Fig. 3).

Il dado per raccordi G 3/4 in plastica deve essere avvitato con un coppia di avvitamento massima di 8 Nm.



Abb. 1



Abb. 2



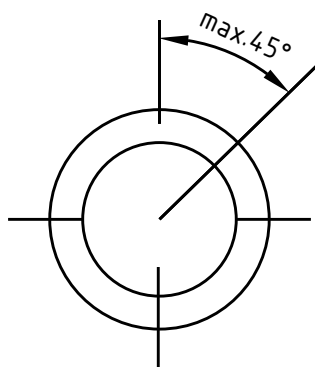



Abb. 3

## 2.5 Collegamento elettrico

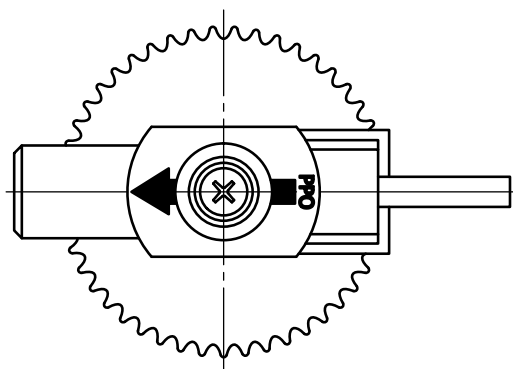
	<p><b>TENSIONE ELETTRICA!</b></p> <p>L'allaccio elettrico deve essere eseguito unicamente da elettricisti esperti. Osservare le disposizioni locali e la VDE 0100. Lo scambiatore di calore deve essere collegato in modo permanente a cavi posati in modo fisso con un fusibile.</p>
	<p><b>ATTENZIONE!</b></p> <p><b>Lo scambiatore di calore elettrico deve essere protetto da almeno due interruttori di sicurezza.</b></p> <p>Le seguenti combinazioni sono offerte franco fabbrica</p> <ul style="list-style-type: none"> <li>- con un termostato di controllo</li> <li>- con un termostato di controllo e un limitatore di temperatura di sicurezza (LTS)</li> <li>- con un termostato di controllo, un LTS e un sensore di flusso.</li> <li>- con un contattore fino a 12 kW.</li> </ul> <p>Se non è installato alcun contattore di fabbrica, è necessario un contattore esterno per azionare il riscaldatore a immersione (per es. Sistema di comando Behncke per EWT 80-xx)</p>
	<p><b>AVVERTENZA!</b></p> <p>Assicurarsi che lo scambiatore di calore elettrico possa essere acceso solo quando è garantito il flusso.</p> <p>I collegamenti elettrici devono essere effettuati secondo lo schema di cablaggio. Per motivi di sicurezza, installare un interruttore differenziale (30 mA) nell'alimentazione elettrica. Tutte le parti metalliche devono essere incluse nel collegamento.</p>

## 2.6 Sensore di flusso

	<p><b>ATTENZIONE!</b></p> <p><b>Pericolo di morte per tensione elettrica!</b></p> <p>Staccare l'impianto elettrico dall'impianto prima di collegare i cavetti dei tubi di collegamento.</p> <p>Marrone/nero = Raccordi per il contatto reed</p> <p>Il contatto reed è integrato in un involucro in plastica come isolamento di protezione (classe di protezione II).</p>
	<p><b>ATTENZIONE!</b></p> <p><b>Pericolo di morte per tensione elettrica!</b></p> <p>Il carico di contatto elettrico max. indicato sulla targhetta non deve mai essere superato in quanto verrebbe danneggiato il contatto reed integrato nell'unità di commutazione. In caso di carichi a induzione, la capacità di commutazione si riduce. Informazioni sul circuito di protezione sono disponibili presso lo stabilimento del produttore.</p>

### 3 Procedura

Nello scambiatore di calore elettrico, il calore è trasferito all'acqua di balneazione dal riscaldatore a immersione.

Il termostato regola la temperatura dell'acqua al livello impostato, intervallo di regolazione: Da 0 a 40°C.

EWT 80- 40/-70: Se la sovrappressione di esercizio necessaria scende al di sotto di 6 kPa (0,06 bar) a causa di un flusso insufficiente, il limitatore di pressione di sicurezza spegne lo scambiatore di calore elettrico.

EWT 80- 41/-71: Se la sovrappressione di esercizio necessaria scende al di sotto di 36,0 l/min a causa di un flusso insufficiente, il sensore di flusso spegne lo EWT.

Opzione: Termostato di sicurezza

Il limitatore di temperatura di sicurezza protegge dal surriscaldamento. Spegne lo scambiatore di calore elettrico ad una temperatura di 44°C.

Premendo il tasto reset lo scambiatore di calore elettrico può essere riportato alla modalità di funzionamento normale dopo l'eliminazione di un guasto.

### 4 Messa in funzione

Le presenti istruzioni per l'uso, in particolare il capitolo 1 Sicurezza, è stato letto e compreso? Prima di ciò non è consentito utilizzare lo scambiatore di calore elettrico!

- Impostare la temperatura dell'acqua di balneazione desiderata sul termostato.

Finché la temperatura impostata non viene raggiunta, lo scambiatore di calore elettrico riscalda l'acqua di balneazione.

	<p><b>ATTENZIONE!</b></p> <p><b>Lo scambiatore di calore elettrico può essere danneggiato.</b></p> <p>Per motivi di sicurezza, i lavori ai tubi e alle installazioni elettriche devono essere eseguiti da tecnici specializzati.</p> <p>Non salire sopra lo scambiatore di calore elettrico.</p> <p>Svolgere le operazioni di manutenzione e pulizia soltanto con i dispositivi di bloccaggio chiusi con circuito d'acqua!</p> <p>Ventilare l'intero circuito dell'acqua, altrimenti l'elemento riscaldante può essere danneggiato.</p>
---	---

### 5 Manutenzione ordinaria / straordinaria

Controllare settimanalmente che lo scambiatore di calore elettrico e le connessioni non presentino perdite e ventilare l'intero circuito dell'acqua.

	<p><b>ATTENZIONE!</b></p> <p><b>Lo scambiatore di calore elettrico può essere danneggiato.</b></p> <p>Per motivi di sicurezza, i lavori allo scambiatore di calore elettrico devono essere eseguiti solo da personale qualificato.</p> <p>Non salire sopra lo scambiatore di calore elettrico.</p> <p>I lavori sui raccordi delle tubazioni devono essere eseguiti solo con i dispositivi di bloccaggio del circuito dell'acqua chiusi!</p>
---	---

## 5.1 Svernare l'EWT nelle stanze senza gelo

	<p><b>ATTENZIONE!</b></p> <p>Gli interventi agli impianti tecnici da parte di persone non competenti possono causare lesioni e danni materiali.</p> <p>In caso di spegnimento in locali senza gelo, lo scambiatore di calore elettrico deve essere completamente riempito d'acqua o completamente vuoto.</p>
---	--

## 5.2 Svernare l'EWT nelle stanze a rischio di gelo

	<p><b>ATTENZIONE!</b></p> <p>Un adeguato svernamento senza danni da gelo è possibile se si seguono i seguenti passi.</p> <ul style="list-style-type: none"> <li>• Chiudere le valvole d'arresto del circuito d'acqua. (I dispositivi di blocco devono essere installati nelle stanze senza gelo)</li> <li>• Svuotare lo scambiatore di calore elettrico e le tubazioni di collegamento fino ai dispositivi di chiusura.</li> </ul>
---	--

### 5.2.1 Scambiatore di calore elettrico in posizione verticale

Scaricare completamente lo scambiatore di calore elettrico tramite le valvole di scarico.

### 5.2.2 Svernare l'EWT in posizione orizzontale

Smontare lo scambiatore di calore elettrico in posizione orizzontale.

Sciaccare lo scambiatore di calore elettrico per rimuovere la sporcizia e conservare in luogo asciutto.

## 6 Guasti e risoluzione

Guasto	Verifica delle possibili cause
Nessuna potenza	<p>Lo scambiatore di calore elettrico è collegato alla rete elettrica? I dispositivi di blocco nel circuito d'acqua sono aperti?</p> <p>Lo scambiatore di calore elettrico è completamente riempito d'acqua?</p> <p>Lo scambiatore di calore elettrico è stato ventilato?</p>
Lo scambiatore di calore elettrico continua a riscaldarsi anche se la pompa di circolazione dell'acqua di balneazione è spenta	<p>C'è un flusso d'acqua sufficiente attraverso lo scambiatore di calore elettrico (vedi dati tecnici)?</p> <p>Il blocco tra la pompa dell'acqua di balneazione e lo scambiatore di calore elettrico è attivo?</p>

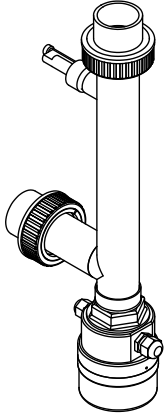

# BEDIENINGSHANDLEIDING

**EWT-80-40/-41**

**EWT-80-70/-71**

**Elektrische  
warmtewisselaar**



## **BEHNCKE GmbH**

### **Beieren:**

Michael-Haslbeck Straße 13  
D-85640 Putzbrunn

Tel.: +49 (0)89 / 45 69 17-0  
Fax: +49 (0)89 / 45 69 17-61

### **Sachsen-Anhalt:**

Stötterlinger Straße 36 a  
D-38835 Bühne

Tel.: +49 (0)39421 / 796-0  
Fax: +49 (0)39421 / 796-30

**E-mail:**            [info@behncke.com](mailto:info@behncke.com)  
**Internet:**        [www.behncke.com](http://www.behncke.com)

## **Inhoudsopgave**

<b>1</b>	<b>Veiligheid</b>	<b>1</b>
1.1	Gevaren bij de omgang met deze elektrische warmtewisselaar	1
1.2	Veiligheidsinstructies en tips	1
1.3	Beoogd gebruik	2
1.4	Gevaarbronnen	3
1.5	Veiligheidsmaatregelen op de plaats van opstelling	3
1.6	Veiligheidsvoorzieningen	4
<b>2</b>	<b>Opstellen en installeren</b>	<b>5</b>
2.1	Transporteren/opslaan	5
2.2	Opstellen	5
2.3	Installeren	5
2.4	Wateraansluiting	6
2.4.1	<i>Installatieaanbrenging boven de waterspiegel</i>	6
2.4.2	<i>Installatieaanbrenging onder de waterspiegel</i>	7
2.4.3	<i>Aansluiting van de elektrische warmtewisselaar op het watercircuit van een filterinstallatie</i>	8
2.4.4	<i>Algemene inbouw instructies voor de stromingsschakelaar</i>	8
2.5	Elektrische aansluiting	9
2.6	Stromingsschakelaar	9
<b>3</b>	<b>Funcieverloop</b>	<b>10</b>
<b>4</b>	<b>Inbedrijfstelling</b>	<b>10</b>
<b>5</b>	<b>Onderhoud / reparatie</b>	<b>10</b>
5.1	De EWT opslaan voor de winter in vorstvrije ruimten	11
5.2	De EWT opslaan voor de winter in ruimten met vorstrisico	11
5.2.1	<i>Elektrische warmtewisselaar in verticale opstelling</i>	11
5.2.2	<i>De EWT opslaan voor de winter in horizontale opstelling</i>	11
<b>6</b>	<b>Storingen en remedies</b>	<b>11</b>
<b>7</b>	<b>Technische afbeeldingen</b>	<b>Tabblad: Technische afbeeldingen</b>
<b>8</b>	<b>Conformiteitsverklaring</b>	<b>Tabblad: Technische afbeeldingen</b>

## 1 Veiligheid

### 1.1 Gevaren bij de omgang met deze elektrische warmtewisselaar

De elektrische warmtewisselaar is gebouwd volgens de stand der techniek en de erkende veiligheidstechnische regels. Toch kunnen er tijdens het gebruik gevaren ontstaan, namelijk

- letsel van de bediener of
- van derden dan wel
- schade aan de elektrische warmtewisselaar of
- andere materiële schade.

Alle personen die te maken hebben met installatie, inbedrijfstelling, bediening, service en onderhoud van de elektrische warmtewisselaar, moeten

- voldoende gekwalificeerd zijn;
- deze installatie-instructies zorgvuldig in acht nemen.

Dit apparaat is niet bestemd om te worden gebruikt door personen (inclusief kinderen) met verminderde lichamelijke, zintuiglijke of geestelijke vermogens of met gebrek aan ervaring en/of kennis, tenzij zij onder toezicht staan of instructies hebben gekregen betreffende het gebruik van het apparaat van een persoon die verantwoordelijk is voor hun veiligheid.

De elektrische warmtewisselaar mag alleen worden gebruikt





- voor het beoogde gebruik;
- in veiligheidstechnisch feilloze toestand.

Bij storingen die de veiligheid in het gedrang kunnen brengen, moet principieel een elektricien worden geraadpleegd.

In ruimten waar elektrische apparaten in gebruik zijn, moet een rookmelder zijn geïnstalleerd!

Het gaat om uw veiligheid.

### 1.2 Veiligheidsinstructies en tips

Symbol	Signaalwoord / betekenis
	<b>GEVAAR</b> Wijst op een gevaarlijke situatie die een ernstige verwonding of de dood tot gevolg zal hebben indien deze niet voorkomen wordt.
	<b>WAARSCHUWING</b> Wijst op een mogelijk gevaarlijke situatie die de dood of ernstige verwondingen tot gevolg kan hebben indien deze niet voorkomen wordt.
	<b>VOORZICHTIG</b> Wijst op een gevaarlijke situatie die een lichte tot matige verwonding tot gevolg kan hebben indien deze niet voorkomen wordt.
	<b>LET OP</b> Vestigt de aandacht op mogelijke materiële schade en andere belangrijke informatie.

Het niet in acht nemen van deze instructie kan leiden tot storingen in het systeem of in de omgeving.

### 1.3 Beoogd gebruik

De elektrische warmtewisselaar is uitsluitend bedoeld voor opwarming van zwembadwater wanneer de circulatie- of filterpomp is ingeschakeld.

Ander of verdergaand gebruik geldt als niet beoogd. Voor hieruit voortvloeiende schade aanvaardt de fabrikant, BEHNCKE® GmbH, geen aansprakelijkheid.

Ander gebruik is uitsluitend mogelijk na afspraak met en goedkeuring door de fabrikant.

	<p><b>OPMERKING!</b></p> <p>Tot het beoogde gebruik behoort ook</p> <ul style="list-style-type: none"> <li>- het in acht nemen van alle instructies in de installatiehandleiding en</li> <li>- het naleven van de inspectie- en onderhoudswerkzaamheden</li> </ul> <p>De maximaal toelaatbare bedrijfsdruk van 300 kPa (3 bar) mag niet worden overschreden.</p> <p>De minimaal vereiste bedrijfsdruk van 10 kPa (0,1 bar) mag niet worden onderschreden.</p> <p>Het minimale debiet bedraagt 1000 l/h.</p>
---	---

**Alleen water met de volgende waarden mag worden gebruikt:**

#### **EWT 80-40/-41, 80-70/-71**

Chloridegehalte	max. 500 mg/l
vrij chloor	max. 1,3 mg/l
pH	6,8 - 8,2
Langelier-index	-0,3 – +0,3

**De specifieke waterweerstand mag niet minder zijn dan  $\leq 1100 \Omega \text{ cm}$  bij 15 °C.**

Om veiligheidsredenen zijn ombouwwerkzaamheden en veranderingen aan de elektrische warmtewisselaar verboden.

Onderhouds- en reparatiewerkzaamheden aan de buisleidingen en elektrische installatie mogen om veiligheidsredenen uitsluitend door vakpersoneel worden uitgevoerd.

## 1.4 Gevaarbronnen

	<p><b>VOORZICHTIG!</b></p> <p><b>De elektrische warmtewisselaar kan beschadigd raken.</b></p> <p>Als de maximale bedrijfsdruk van 300 kPa (3,0 bar) wordt overschreden, kan de elektrische warmtewisselaar gaan lekken.</p>
	<p><b>VOORZICHTIG!</b></p> <p><b>Er bestaat verbrandingsgevaar.</b></p> <p>De aansluitingen en de elektrische warmtewisselaar kunnen temperaturen tot 100 °C bereiken.</p> <p>Indien het waterdebiet onvoldoende is (&lt; 1000 l/h), kan de elektrische warmtewisselaar aanzienlijk oververhitten.</p> <p>De inbouw van een stromingssensor als extra veiligheidsvoorziening wordt in het algemeen aanbevolen.</p>
	<p><b>VOORZICHTIG!</b></p> <p><b>De elektrische warmtewisselaar kan beschadigd raken.</b></p> <p>Door waterdruppels op de externe behuizing of door het naar binnen spoelen van metaaldeeltjes in de elektrische warmtewisselaar bestaat gevaar voor contactcorrosie.</p>

## 1.5 Veiligheidsmaatregelen op de plaats van opstelling

De elektrische warmtewisselaar moet worden geïnstalleerd in een vorstvrije ruimte met een houder van roestvrij staal of kunststof.

Zorg ervoor dat de maximale bedrijfsdruk van 300 kPa (3,0 bar) niet overschreden wordt.

	<p><b>VOORZICHTIG!</b></p> <p>De elektrische warmtewisselaar of de omgeving kan schade oplopen.</p> <p>Controleer ten minste eenmaal per week tijdens de openingsuren van het zwembad de elektrische warmtewisselaar en zijn aansluitingen op dichtheid en uiterlijk herkenbare schade.</p>
	<p><b>VOORZICHTIG!</b></p> <p><b>Er is brandgevaar.</b></p> <p>Indien het waterdebiet onvoldoende is (&lt; 1000 l/h), kan de elektrische warmtewisselaar aanzienlijk oververhitten.</p> <p>Sla geen ontvlambare materialen op in de nabijheid.</p> <p>De inbouw van een stromingssensor als extra veiligheidsvoorziening wordt in het algemeen aanbevolen.</p> <p>Deze voorkomt ook dat de verwarmingsweerstand doorbrandt bij stilstand van het water.</p>

**VOORZICHTIG!****De elektrische warmtewisselaar kan beschadigd raken.**

De elektrische warmtewisselaar mag alleen in bedrijf worden gesteld indien verzekerd is dat de elektrische warmtewisselaar tijdens de werking voortdurend van water wordt voorzien. Het waterdebiet moet ten minste 1000 l/h bedragen.

**1.6 Veiligheidsvoorzieningen**

Het waarschuwbord op de elektrische warmtewisselaar waarschuwt voor het gevaar door elektrische stroom.

De elektrische warmtewisselaar is voorzien van een veiligheidsdrukbegrenzer.

De veiligheidsdrukbegrenzer dient als bescherming tegen een tekort aan water (zie EWT 80-40 of -70).

**VOORZICHTIG!**

De elektrische warmtewisselaar moet door ten minste twee veiligheidsschakelaars worden beveiligd.

Af fabriek worden de volgende combinaties aangeboden

- met een veiligheidstemperatuurbegrenzer
- met een regelthermostaat en een veiligheidstemperatuurbegrenzer (STB)
- met een regelthermostaat, een STB en stromingsschakelaar
- met een zekering tot 12 kW.

Als er in de fabriek geen zekering is geïnstalleerd, is een externe zekering nodig om de verwarmingsstaaf te schakelen (bijv. Behncke ®-besturing voor EWT 80-xx).

Besturing met een zekering:	3–12 kW	Art.Nr. 304 006 12
	15–18 kW	Art.Nr. 304 006 18

Besturing met ingebouwde tweede zekering voor veiligheidsuitschakeling met controlelampje (dringend aanbevolen) voor EWT 80-41/-71 met regeling en veiligheidsthermostaat:

	3–12 kW	Art.Nr. 304 007 12
	15–18 kW	Art.Nr. 304 007 18

– Schakelkast niet bij de levering inbegrepen! –

De veiligheidsvoorzieningen schakelen de elektrische warmtewisselaar uit wanneer ontoelaatbare waarden worden bereikt.

## 2 Opstellen en installeren

### 2.1 Transporteren/opslaan

Transporteer de elektrische warmtewisselaar uitsluitend geledigd.

Sla de gespoelde en geledigde elektrische warmtewisselaar uitsluitend op in binnenruimten met een niet-agressieve atmosfeer.

### 2.2 Opstellen

Installeer de elektrische warmtewisselaar alleen in vorstvrije, droge ruimten met een niet-agressieve atmosfeer.

Druppelend water kan de elektrische warmtewisselaar beschadigen.

Zorg voor een gemakkelijke toegankelijkheid voor montage en demontage.

	<p><b>VOORZICHTIG!</b></p> <p>Voor de elektrische warmtewisselaar moeten altijd de volgende waterwaarden in acht worden genomen.</p> <p><b>EWT 80-40/-41, 80-70/-71</b></p> <table><tbody><tr><td>Chloridegehalte</td><td>max. 500 mg/l</td></tr><tr><td>vrij chloor</td><td>max. 1,3 mg/l</td></tr><tr><td>pH</td><td>6,8 - 8,2</td></tr><tr><td>Langelier-index</td><td>-0,3 – +0,3</td></tr><tr><td>Waterdebiet</td><td>min. 1000 l/h</td></tr><tr><td>min. bedrijfsdruk</td><td>10 kPa (0,1 bar)</td></tr><tr><td>max. bedrijfsdruk</td><td>300 kPa (3,0 bar)</td></tr></tbody></table>	Chloridegehalte	max. 500 mg/l	vrij chloor	max. 1,3 mg/l	pH	6,8 - 8,2	Langelier-index	-0,3 – +0,3	Waterdebiet	min. 1000 l/h	min. bedrijfsdruk	10 kPa (0,1 bar)	max. bedrijfsdruk	300 kPa (3,0 bar)
Chloridegehalte	max. 500 mg/l														
vrij chloor	max. 1,3 mg/l														
pH	6,8 - 8,2														
Langelier-index	-0,3 – +0,3														
Waterdebiet	min. 1000 l/h														
min. bedrijfsdruk	10 kPa (0,1 bar)														
max. bedrijfsdruk	300 kPa (3,0 bar)														
	<p><b>VOORZICHTIG!</b></p> <p>Bij uitval van de veiligheidsvoorzieningen bestaat brandgevaar.</p> <p>Oververhitting van de elektrische warmtewisselaar kan brand veroorzaken.</p> <p>Het leeglopen van de elektrische warmtewisselaar tijdens de werking moet worden voorkomen.</p> <p>Sla geen ontvlambare materialen op in de nabijheid.</p>														

### 2.3 Installeren

Vóór de installatie moet worden gecontroleerd dat de elektrische warmtewisselaar geen zichtbare beschadigingen vertoont.

De elektrische warmtewisselaar kan horizontaal of verticaal boven of onder de waterspiegel geïnstalleerd worden.

Bij installatie boven of onder 0,50 m van de waterspiegel verliest de veiligheidsdrukschakelaar (beveiliging tegen tekort aan water) zijn werking.

In dit geval is een Behncke ®-stromingsschakelaar absoluut noodzakelijk in plaats van de drukschakelaar. (zie EWT 80-41/-71)

## 2.4 Wateraansluiting

### 2.4.1 Installatieaanbrenging boven de waterspiegel

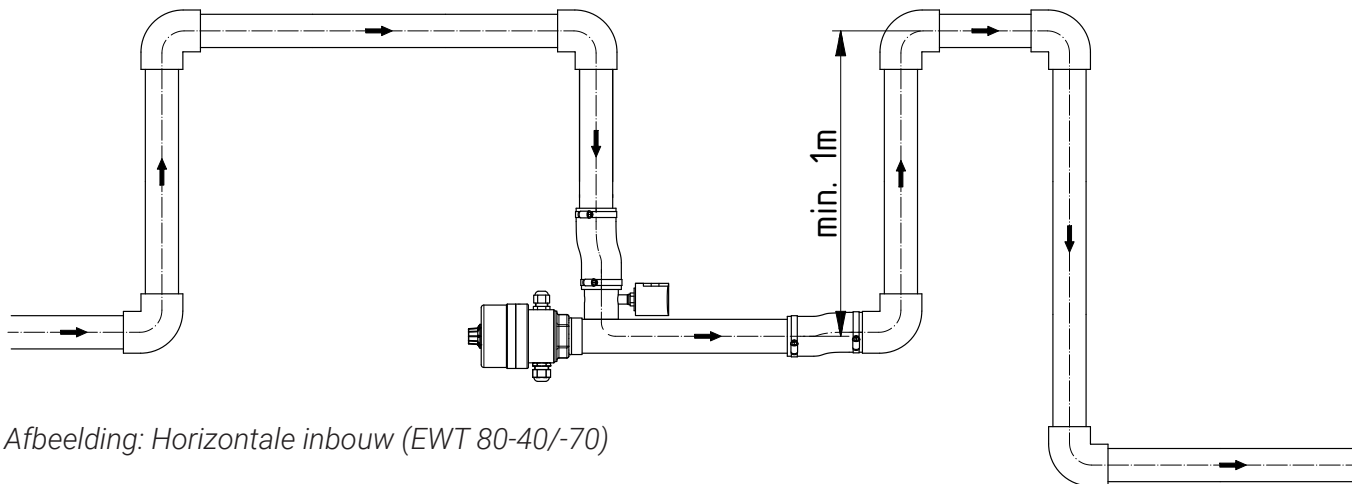

Afbeelding: Horizontale inbouw (EWT 80-40/-70)

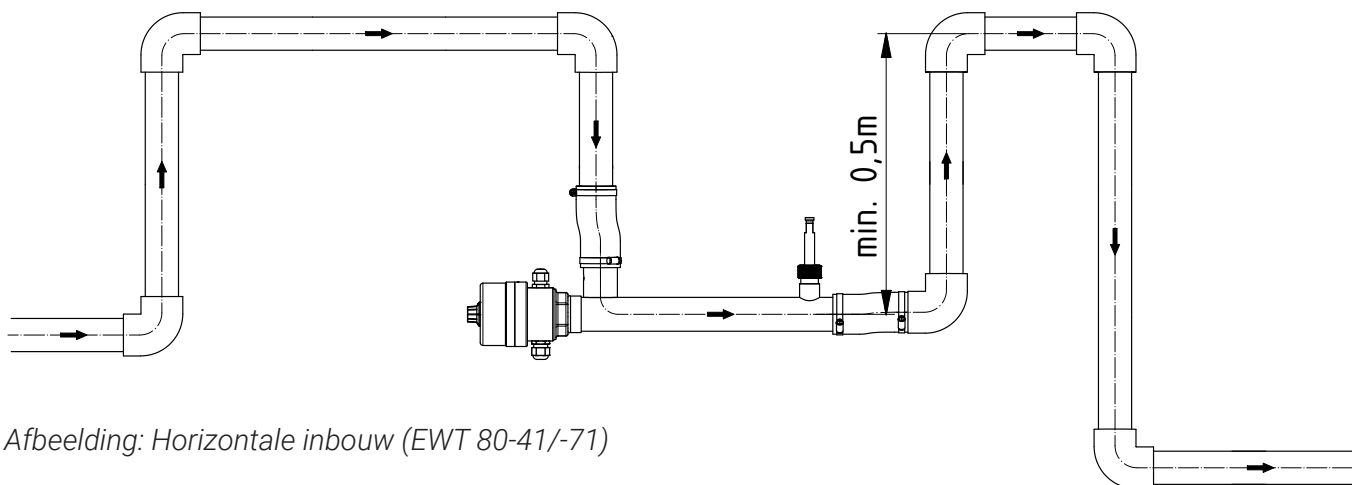

Afbeelding: Horizontale inbouw (EWT 80-41/-71)

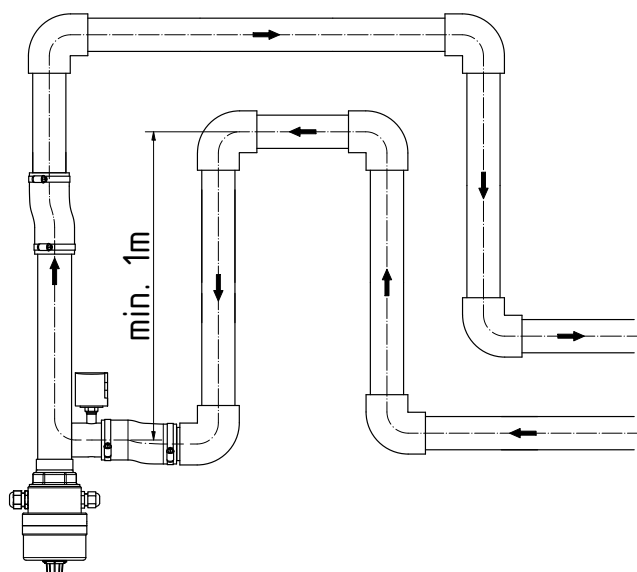

Afbeelding: Verticale inbouw (EWT 80-40/-70)

### 2.4.2 Installatieaanbrenging onder de waterspiegel

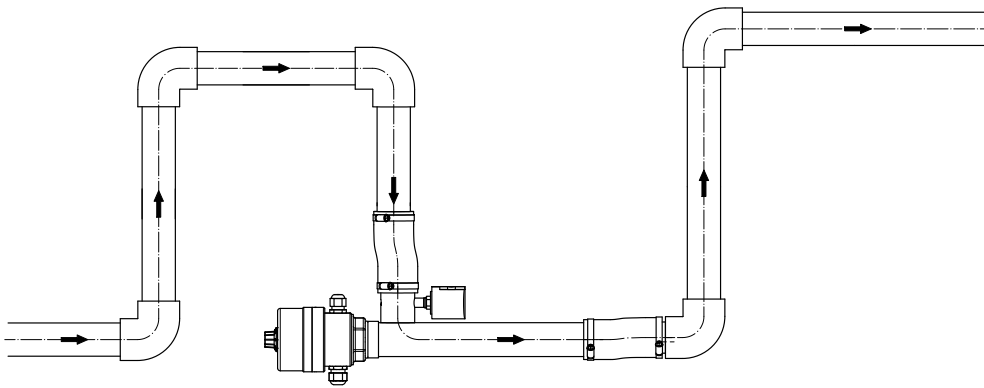

Afbeelding: Horizontale inbouw (EWT 80-40/-70)

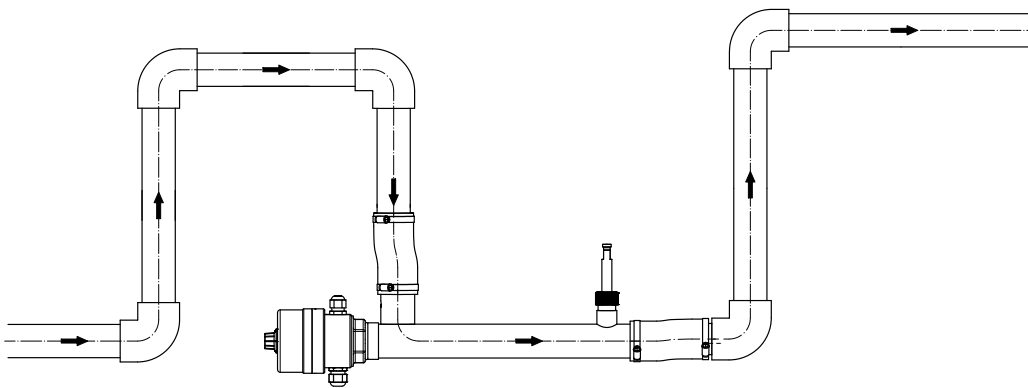

Afbeelding: Horizontale inbouw (EWT 80-41/-71)

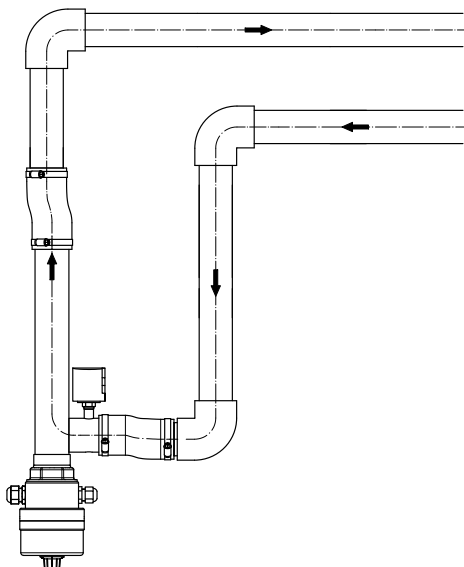



Afbeelding: Verticale inbouw (EWT 80-40/-70)

### 2.4.3 Aansluiting van de elektrische warmtewisselaar op het watercircuit van een filterinstallatie

Installeer de elektrische warmtewisselaar in de drukleiding (naar het bassin) na de pomp en het filter.

De EWT 80-40/-41 wordt op het watercircuit aangesloten via de 1 1/2" binnendraad of via slangverbindingen met slangklemmen.

De EWT 80-70/-71 wordt op het watercircuit aangesloten met zelfklevende PVC-schroefverbindingen d50.

	<p><b>VOORZICHTIG!</b></p> <p>De elektrische warmtewisselaar kan beschadigd raken.</p> <p>Let er bij het aansluiten op het watercircuit op dat er geen metalen deeltjes in de elektrische warmtewisselaar komen.</p>
	<p><b>VOORZICHTIG!</b></p> <p><b>De elektrische warmtewisselaar kan door chemicaliën beschadigd raken.</b></p> <p>Ontsmettingstoestellen moeten principieel na de elektrische warmtewisselaar worden geïnstalleerd. De afstand moet ten minste 1 m bedragen en de volgorde: eerst hardheidsregeling, dan toevoegen van chloor, moet in acht worden genomen.</p> <p>Bij gebruik van chemicaliën (bv. chloorgas) mogen tijdens de stilstandstijden van het filter geen gasen in de elektrische warmtewisselaar dringen.</p>

### 2.4.4 Algemene inbouw instructies voor de stromingsschakelaar

Het kalmeringstraject voor en achter de stromingscontroleschakelaar moet ten minste 5 x DN zijn.

De stromingscontroleschakelaar mag alleen in een horizontale leiding worden ingebouwd.

Bij afwijkende inbouwposities moet u de fabrikant raadplegen.

De schakelaars mogen alleen verticaal worden ingebouwd, afwijking max. 45° (zie afb. 1).

Zorg ervoor dat de werking van de stromingscontroleschakelaar niet beïnvloed kan worden door externe magnetische velden in de onmiddellijke nabijheid van het apparaat (zie afb. 2).

Op de stromingscontroleschakelaar staat een pijl. Zorg er bij de inbouw voor dat deze altijd evenwijdig loopt met de as van de buis en in de richting van de stroming wijst (zie afb. 3).

De kunststof wartelmoer G 3/4 moet met een maximaal aandraaimoment van 8 Nm worden aangedraaid.



Abb. 1



Abb. 2

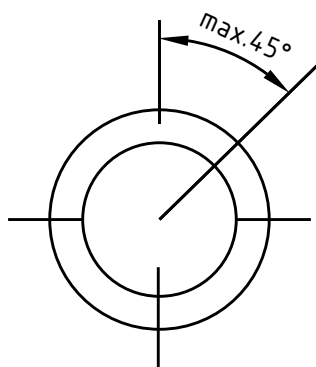

Abb. 3

## 2.5 Elektrische aansluiting

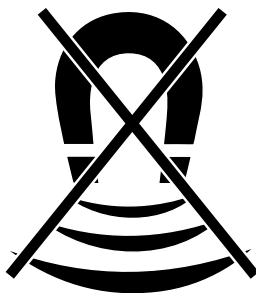
	<p><b>ELEKTRISCHE SPANNING!</b></p> <p>De elektrische aansluiting mag uitsluitend door een professioneel elektricien uitgevoerd worden. Hierbij moet rekening gehouden worden met de plaatselijke voorschriften alsmede de regels van VDE 0100. De warmtewisselaar moet permanent worden aangesloten op permanent gelegde kabels met een aardleiding.</p>
	<p><b>VOORZICHTIG!</b></p> <p><b>De elektrische warmtewisselaar moet door ten minste twee veiligheidsschakelaars worden beveiligd.</b></p> <p>Af fabriek worden de volgende combinaties aangeboden</p> <ul style="list-style-type: none"> <li>– met een regelthermostaat</li> <li>– met een regelthermostaat en een veiligheidstemperatuurbegrenzer (STB)</li> <li>– met een regelthermostaat, een STB en een stromingsschakelaar.</li> <li>– met een zekering tot 12 kW.</li> </ul> <p>Als er in de fabriek geen zekering is geïnstalleerd, is een externe zekering nodig om de verwarmingsstaaf te schakelen (bijv. Behncke-besturing voor EWT 80-xx).</p>
	<p><b>OPMERKING!</b></p> <p>Er moet op worden toegezien dat de elektrische warmtewisselaar alleen kan worden ingeschakeld wanneer de doorstroming gewaarborgd is.</p> <p>De elektrische aansluitingen moeten worden uitgevoerd volgens het schakelschema.</p> <p>Om veiligheidsredenen moet in de spanningstoevoer een lekschakelaar (30 mA) worden ingebouwd. Alle metalen onderdelen moeten in de potentiaalvereffening worden opgenomen.</p>

## 2.6 Stromingsschakelaar

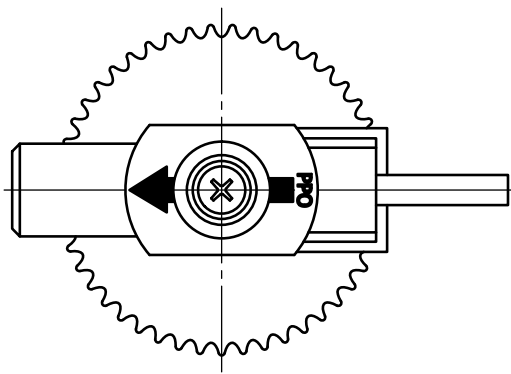
	<p><b>VOORZICHTIG!</b></p> <p><b>Levensgevaar door elektrische spanning!</b></p> <p>Schakel de elektrische installatie spanningsloos alvorens u de draden van de aansluitkabel aansluit.</p> <p>bruin/zwart = aansluitingen voor het reed-contact</p> <p>Het reed-contact is geïntegreerd in een kunststof huls met beschermende isolatie (veiligheidsklasse II).</p>
	<p><b>VOORZICHTIG!</b></p> <p><b>Levensgevaar door elektrische spanning!</b></p> <p>De op het typeplaatje aangegeven max. elektrische contactbelasting mag in geen geval worden overschreden, omdat anders het in de schakeleenheid geïntegreerde reed-contact wordt beschadigd. Bij inductieve lasten neemt het schakelvermogen af. Informatie over de veiligheidsschakeling kan worden verkregen bij de fabrikant.</p>

### 3 Functieverloop

In de elektrische warmtewisselaar wordt door de verwarmingsstaaf warmte aan het zwemwater overgedragen.

De thermostaat regelt de watertemperatuur op het ingestelde niveau, instelbereik: 0 tot 40 °C.

EWT 80-40/-70: Als de vereiste bedrijfsdruk door een gebrek aan doorstroming onder 6 kPa (0,06 bar) daalt, schakelt de veiligheidsdrukbegrenzer de elektrische warmtewisselaar uit.

EWT 80-41/-71: Als de vereiste bedrijfsdruk door onvoldoende doorstroming onder de 36,0 l/min. daalt, schakelt de stromingsschakelaar de EWT uit.

Optie: veiligheidsthermostaat

De veiligheidstemperatuurbegrenzer beschermt tegen oververhitting. Hij schakelt de elektrische warmtewisselaar uit bij een temperatuur van 44 °C.

Door het indrukken van de ontstoringsknop kan de elektrische warmtewisselaar na het verhelpen van een storing weer in de normale stand-bytoestand worden gebracht.

### 4 Inbedrijfstelling

Heeft u deze gebruiksaanwijzing – in het bijzonder hoofdstuk 1, Veiligheid – gelezen en begrepen? Eerder mag u de elektrische warmtewisselaar niet in gebruik nemen!

- Stel op de thermostaat de gewenste temperatuur van het zwemwater in.

Zolang de ingestelde temperatuur niet is bereikt, verwarmt de elektrische warmtewisselaar het zwemwater.

	<p><b>VOORZICHTIG!</b></p> <p><b>De elektrische warmtewisselaar kan beschadigd raken.</b></p> <p>Werkzaamheden aan de buisleidingen en de elektrische installatie mogen om veiligheidsredenen uitsluitend door vakpersoneel worden uitgevoerd.</p> <p>Klim niet op de elektrische warmtewisselaar.</p> <p>Voer onderhouds- en reinigingswerkzaamheden uitsluitend uit wanneer de afsluitelementen in het watercircuit gesloten zijn!</p> <p>Ontlucht het hele watercircuit, anders kan het verwarmingselement beschadigd raken.</p>
---	---

### 5 Onderhoud / reparatie

Controleer wekelijks de elektrische warmtewisselaar en de aansluitingen op dichtheid en ontlucht het gehele watercircuit.

	<p><b>VOORZICHTIG!</b></p> <p><b>De elektrische warmtewisselaar kan beschadigd raken.</b></p> <p>Werkzaamheden aan de elektrische warmtewisselaar mogen om veiligheidsredenen alleen worden uitgevoerd door vakpersoneel.</p> <p>Klim niet op de elektrische warmtewisselaar.</p> <p>Werkzaamheden aan de buisaansluitingen mogen alleen worden uitgevoerd met gesloten afsluitelementen in het watercircuit!</p>
---	---

## 5.1 De EWT opslaan voor de winter in vorstvrije ruimten

	<p><b>VOORZICHTIG!</b></p> <p>Ingrepen aan technische installaties door onkundige personen kunnen tot verwondingen en materiële schade leiden.</p> <p>Bij stilleggen in vorstvrije ruimten moet de elektrische warmtewisselaar compleet met water gevuld of compleet geledigd zijn.</p>
---	---

## 5.2 De EWT opslaan voor de winter in ruimten met vorst risico

	<p><b>VOORZICHTIG!</b></p> <p>Het laten overwinteren zonder vorstschade is mogelijk mits naleving van de volgende werkstappen.</p> <ul style="list-style-type: none"> <li>• Afsluitelementen in het watercircuit sluiten. (Afsluitelementen moeten in vorstvrije ruimten zijn geïnstalleerd)</li> <li>• Elektrische warmtewisselaar en aansluitende buisleidingen doorspoelen en ledigen tot aan de afsluitelementen.</li> </ul>
---	--

### 5.2.1 Elektrische warmtewisselaar in verticale opstelling

Elektrische warmtewisselaar compleet ledigen via ledigingskranen.

### 5.2.2 De EWT opslaan voor de winter in horizontale opstelling

Verwijder de elektrische warmtewisselaar in een horizontale opstelling.

Spoel de elektrische warmtewisselaar om onzuiverheden te verwijderen en bewaar hem op een droge plaats.

## 6 Storingen en remedies

Fout	Controleer de mogelijke oorzaak
Geen vermogen	<p>Is de elektrische warmtewisselaar elektrisch aangesloten? Zijn de afsluitelementen in het watercircuit geopend?</p> <p>Is de elektrische warmtewisselaar volledig gevuld met water?</p> <p>Werd de elektrische warmtewisselaar ontlucht?</p>
De elektrische warmtewisselaar blijft verwarmen, ook al is de circulatiepomp van het zwembad uitgeschakeld	<p>Is er voldoende waterdoorstroming door de elektrische warmtewisselaar (zie technische gegevens)?</p> <p>Is de vergrendeling tussen de zwembadpomp en de elektrische warmtewisselaar actief?</p>

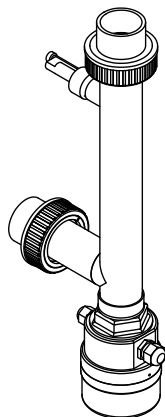

# РУКОВОДСТВО ПО ЭКСПЛУАТАЦИИ

**EWT-80-40/-41**

**EWT-80-70/-71**

**Электрический  
теплообменник**



## **ВЕHNCKE GmbH**

### **Бавария:**

Michael-Haslbeck Straße 13  
D-85640 Putzbrunn (Германия)

Тел.: +49 (0)89 / 45 69 17-0  
Факс: +49 (0)89 / 45 69 17-61

### **Саксония-Анхальт:**

Stötterlinger Straße 36 a  
D-38835 Bühne (Германия)

Тел.: +49 (0)39421 / 796-0  
Факс: +49 (0)39421 / 796-30

**Эл. почта:** [info@behncke.com](mailto:info@behncke.com)  
**Сайт:** [www.behncke.com](http://www.behncke.com)

## Оглавление

<b>1</b>	<b>Техника безопасности</b>	<b>1</b>
1.1	Опасности, возникающие при эксплуатации электрического теплообменника	1
1.2	Указания по технике безопасности и рекомендации	1
1.3	Применение по назначению	2
1.4	Источники опасности	3
1.5	Меры безопасности на месте установки	3
1.6	Предохранительные устройства	4
<b>2</b>	<b>Установка и монтаж</b>	<b>5</b>
2.1	Транспортировка/хранение	5
2.2	Установка	5
2.3	Установка	5
2.4	Подключение к сети водоснабжения	6
2.4.1	<i>Установка выше уровня воды</i>	6
2.4.2	<i>Установка ниже уровня воды</i>	7
2.4.3	<i>Подключение электрического теплообменника к водяному контуру фильтровальной установки</i>	8
2.4.4	<i>Общие указания по установке реле потока</i>	8
2.5	Электрическое подключение	9
2.6	Реле потока	9
<b>3</b>	<b>Принцип действия</b>	<b>10</b>
<b>4</b>	<b>Ввод в эксплуатацию</b>	<b>10</b>
<b>5</b>	<b>Техническое обслуживание/ремонт</b>	<b>10</b>
5.1	Хранение электрического теплообменника в зимний период в защищенном от мороза помещении	11
5.2	Хранение электрического теплообменника в неотапливаемом помещении в зимний период	11
5.2.1	<i>Вертикально расположенный электрический теплообменник</i>	11
5.2.2	<i>Хранение горизонтально расположенного электрического теплообменника в зимний период</i>	11
<b>6</b>	<b>Неисправности и их устранение</b>	<b>11</b>
<b>7</b>	<b>Технические иллюстрации</b>	<b>Вкладка: Технические иллюстрации</b>
<b>8</b>	<b>Декларация соответствия</b>	<b>Вкладка: Технические иллюстрации</b>

## 1 Техника безопасности

### 1.1 Опасности, возникающие при эксплуатации электрического теплообменника

Электрический теплообменник сконструирован в соответствии с современным уровнем развития техники и общепризнанными правилами техники безопасности. Однако при его использовании могут возникать опасности, а именно

- травмирование оператора или третьих лиц или
- повреждение электрического теплообменника или
- повреждение другого имущества.

Весь персонал, осуществляющий установку, ввод в эксплуатацию, управление, техническое обслуживание и ремонт

электрического теплообменника, должен

- иметь соответствующую квалификацию.
- точно выполнять указания, приведенные в руководстве по монтажу.

Данное устройство не предназначено для использования лицами (включая детей) с ограниченными физическими, сенсорными или умственными способностями, а также с недостаточным опытом и/или знаниями, если они не прошли инструктаж по использованию устройства от лица, ответственного за их безопасность, или не находятся под его надзором.

Электрический теплообменник необходимо использовать только





- строго по назначению.
- в технически безупречном состоянии.

При наличии неисправностей, влияющих на безопасность, обязательно необходимо обратиться к специалисту-электрику.

В помещениях, где работают электроприборы, должен быть установлен детектор дыма!

Это важно для вашей безопасности.

### 1.2 Указания по технике безопасности и рекомендации

Символ	Сигнальное слово/значение
	<b>ОПАСНО</b> Указывает на опасную ситуацию, которая, если ее не предотвратить, повлечет за собой тяжелую травму или смерть.
	<b>ПРЕДУПРЕЖДЕНИЕ</b> Указывает на потенциально опасную ситуацию, которая, если ее не предотвратить, может повлечь за собой смерть или тяжелые травмы.
	<b>ОСТОРОЖНО</b> Указывает на опасную ситуацию, которая, если ее не предотвратить, может повлечь за собой травму легкой или средней степени тяжести.
	<b>УКАЗАНИЕ</b> Указывает на возможность причинения материального ущерба и другую важную информацию.

Несоблюдение этого указания может привести к неисправностям в установке или в окружающей среде.

### 1.3 Применение по назначению

Электрический теплообменник предназначен исключительно для подогрева воды в бассейне при включенном циркуляционном насосе или фильтр-насосе.

Любое другое или выходящее за указанные рамки использование считается ненадлежащим.

Компания-производитель VEHNCKE® GmbH не несет ответственности за возникший в результате этого ущерб.

Иное применение возможно только после официального согласования с компанией-производителем и с его разрешения.



#### УКАЗАНИЕ!

Применение по назначению подразумевает также

- выполнение всех указаний, приведенных в руководстве по монтажу;
- проведение профилактических осмотров и работ по техническому обслуживанию.

Не допускается превышение максимально допустимого избыточного рабочего давления, составляющего 300 кПа (3 бар).

Не допускается выход за пределы минимально необходимого избыточного рабочего давления, составляющего 10 кПа (0,1 бар).

Минимальная пропускная способность составляет 1000 л/ч.

**Можно использовать только воду со следующими значениями:**

#### **EWT 80-40/-41, 80-70/-71**



Содержание хлоридов	макс. 500 мг/л
Свободный хлор	макс. 1,3 мг/л
Уровень pH	6,8–8,2
Индекс Ланжелье	от –0,3 до +0,3

**Удельное гидравлическое сопротивление должно составлять менее  $\leq 1100 \Omega$  см при 15 °С.**

Модернизация электрического теплообменника и внесение изменений в его конструкцию запрещены в целях обеспечения безопасности.

В целях обеспечения безопасности работы по техническому обслуживанию и ремонту трубопроводов и электропроводки должен выполнять только квалифицированный персонал.



## 1.4 Источники опасности

	<p><b>ОСТОРОЖНО!</b></p> <p><b>Возможно повреждение электрического теплообменника.</b></p> <p>При превышении максимально допустимого избыточного рабочего давления, составляющего 300 кПа (3,0 бар), возможно нарушение герметичности электрического теплообменника.</p>
	<p><b>ОСТОРОЖНО!</b></p> <p><b>Существует опасность ожога.</b></p> <p>Соединительные элементы и электрический теплообменник могут достигать температуры до 100 °С.</p> <p>При недостаточном протоке воды (&lt; 1000 л/ч) возможен сильный перегрев электрического теплообменника.</p> <p>Настоятельно рекомендуется установить датчик потока воды в качестве дополнительного предохранительного устройства.</p>
	<p><b>ОСТОРОЖНО!</b></p> <p><b>Возможно повреждение электрического теплообменника.</b></p> <p>Существует риск контактной коррозии при попадании воды на наружную обшивку или металлические детали электрического теплообменника.</p>

## 1.5 Меры безопасности на месте установки

Электрический теплообменник необходимо установить в защищенном от мороза помещении с использованием крепления из нержавеющей стали или пластика.

Не допускается превышать максимальное рабочее давление 300 кПа (3,0 бар).

	<p><b>ОСТОРОЖНО!</b></p> <p>Возможно повреждение электрического теплообменника или окружающих предметов.</p> <p>Во время эксплуатации бассейна необходимо не реже одного раза в неделю проверять электрический теплообменник и его соединительные элементы на герметичность и наличие видимых повреждений.</p>
	<p><b>ОСТОРОЖНО!</b></p> <p><b>Существует опасность пожара.</b></p> <p>При недостаточном протоке воды (&lt; 1000 л/ч) возможен сильный перегрев электрического теплообменника.</p> <p>Не храните легковоспламеняющиеся материалы в непосредственной близости от теплообменника.</p> <p>Настоятельно рекомендуется установить датчик потока воды в качестве дополнительного предохранительного устройства.</p> <p>Он также предотвращает перегорание нагревательного резистора при прекращении подачи воды.</p>



## 2 Установка и монтаж

### 2.1 Транспортировка/хранение

Транспортировка электрического теплообменника может осуществляться только в опорожненном состоянии.



Промытый и опорожненный электрический теплообменник следует хранить только в помещениях с неагрессивной атмосферой.

### 2.2 Установка

Электрический теплообменник необходимо устанавливать только в сухих, защищенных от мороза помещениях с неагрессивной атмосферой.

Стекающая каплями вода может повредить электрический теплообменник.

Необходимо обеспечить удобный доступ для проведения работ по монтажу и демонтажу оборудования.

	<p><b>ОСТОРОЖНО!</b></p> <p>При эксплуатации электрического теплообменника следует обязательно соблюдать следующие характеристики воды.</p> <p><b>EWT 80-40/-41, 80-70/-71</b></p> <table> <tr> <td>Содержание хлоридов</td> <td>макс. 500 мг/л</td> </tr> <tr> <td>Свободный хлор</td> <td>макс. 1,3 мг/л</td> </tr> <tr> <td>Уровень pH</td> <td>6,8–8,2</td> </tr> <tr> <td>Индекс Ланжелье</td> <td>от –0,3 до +0,3</td> </tr> <tr> <td>Пропускная способность по воде</td> <td>мин. 1000 л/ч</td> </tr> <tr> <td>Мин. рабочее давление</td> <td>10 кПа (0,1 бар)</td> </tr> <tr> <td>Макс. рабочее давление</td> <td>300 кПа (3,0 бар)</td> </tr> </table>	Содержание хлоридов	макс. 500 мг/л	Свободный хлор	макс. 1,3 мг/л	Уровень pH	6,8–8,2	Индекс Ланжелье	от –0,3 до +0,3	Пропускная способность по воде	мин. 1000 л/ч	Мин. рабочее давление	10 кПа (0,1 бар)	Макс. рабочее давление	300 кПа (3,0 бар)
Содержание хлоридов	макс. 500 мг/л														
Свободный хлор	макс. 1,3 мг/л														
Уровень pH	6,8–8,2														
Индекс Ланжелье	от –0,3 до +0,3														
Пропускная способность по воде	мин. 1000 л/ч														
Мин. рабочее давление	10 кПа (0,1 бар)														
Макс. рабочее давление	300 кПа (3,0 бар)														
	<p><b>ОСТОРОЖНО!</b></p> <p>Существует риск возникновения пожара в случае выхода из строя предохранительных устройств.</p> <p>Перегрев электрического теплообменника может привести к пожару.</p> <p>Опорожнение электрического теплообменника во время работы должно быть исключено.</p> <p>Не храните легковоспламеняющиеся материалы в непосредственной близости от теплообменника.</p>														

### 2.3 Установка

Перед установкой необходимо убедиться в отсутствии видимых повреждений электрического теплообменника.

Электрический теплообменник можно устанавливать горизонтально или вертикально выше или ниже уровня воды.

Если устройство установлено выше или ниже 0,50 м от уровня воды, предохранительное реле давления (защита от нехватки воды) теряет свою эффективность.

В этом случае вместо реле давления необходимо установить реле потока Behncke® (см. EWT 80-41/-71).

## 2.4 Подключение к сети водоснабжения

### 2.4.1 Установка выше уровня воды



Рисунок: горизонтальная установка (EWT 80-40/-70)



Рисунок: горизонтальная установка (EWT 80-41/-71)

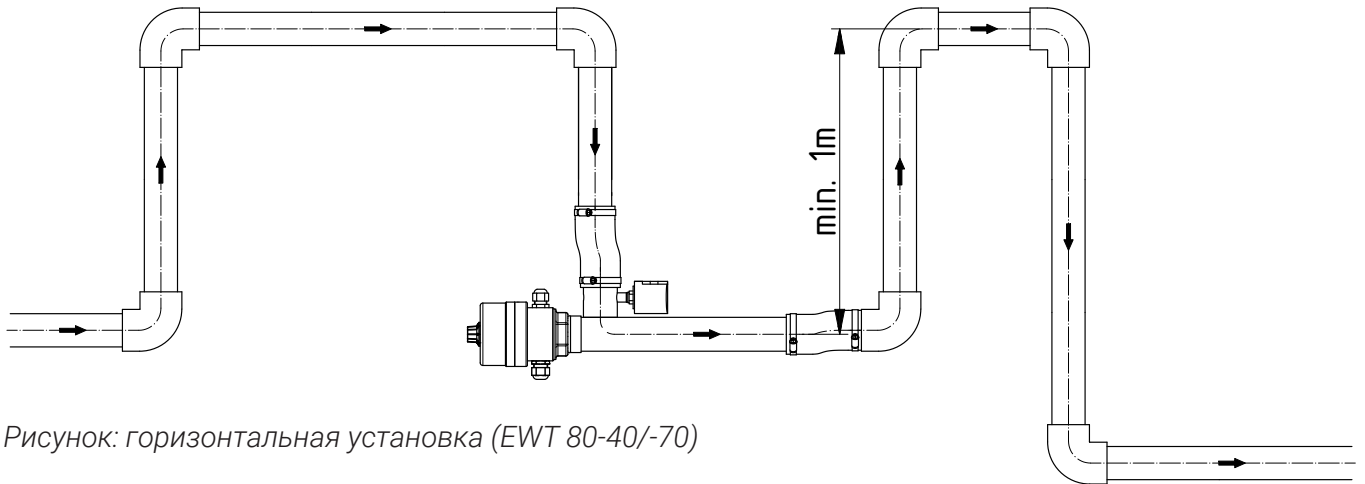

Рисунок: вертикальная установка (EWT 80-40/-70)

### 2.4.2 Установка ниже уровня воды

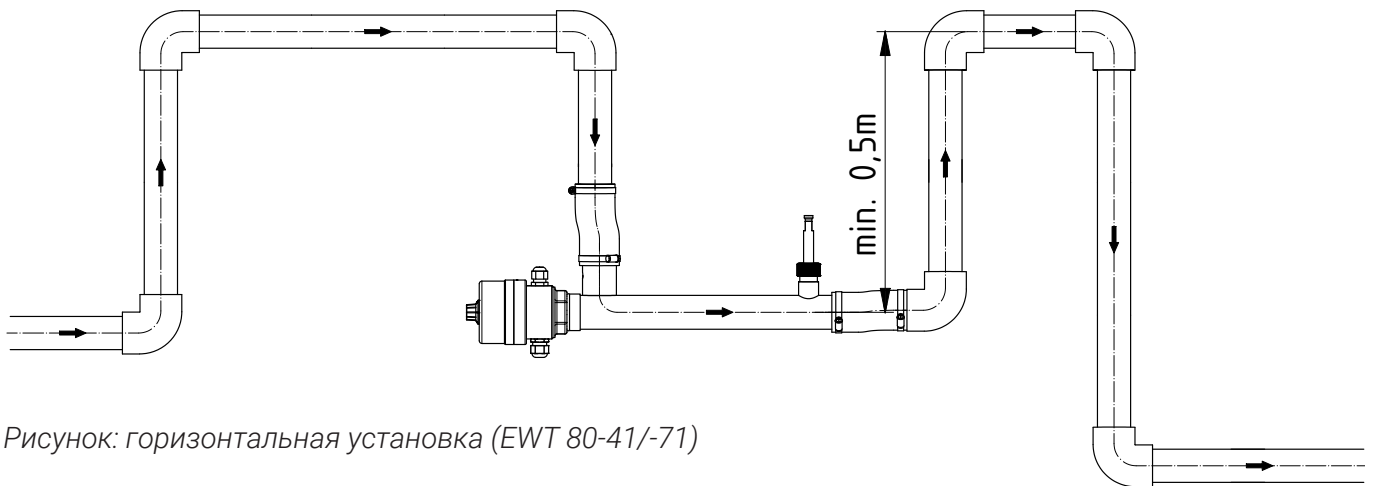

Рисунок: горизонтальная установка (EWT 80-40/-70)

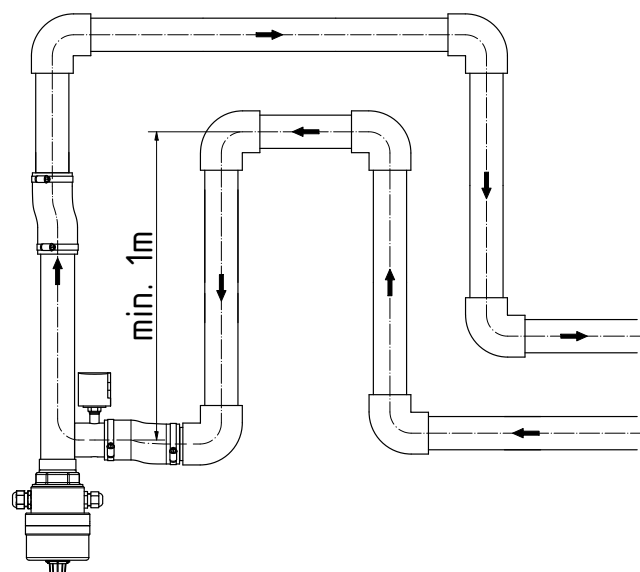

Рисунок: горизонтальная установка (EWT 80-41/-71)

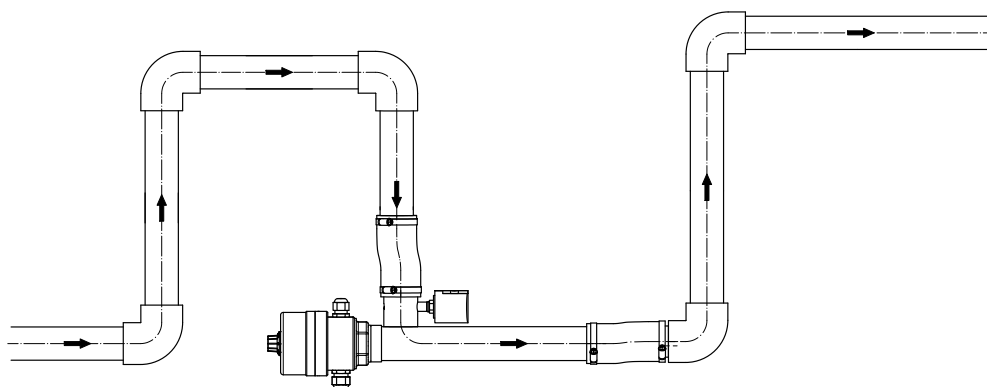

Рисунок: вертикальная установка (EWT 80-40/-70)

### 2.4.3 Подключение электрического теплообменника к водяному контуру фильтровальной установки

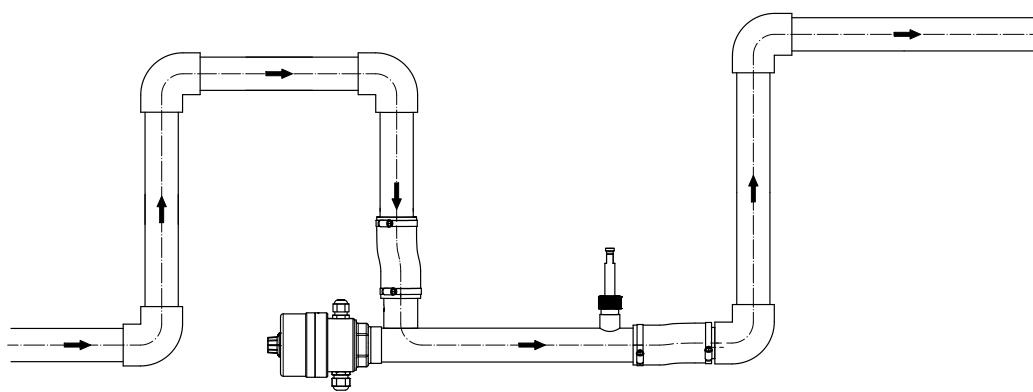
Электрический теплообменник следует установить в напорной линии (ведущей к бассейну) после насоса и фильтра.

Встраивание EWT 80-40/-41 в водяной контур фильтровальной установки осуществляется через внутреннюю резьбу 1 1/2" или через шланговые соединения с помощью шланговых зажимов.

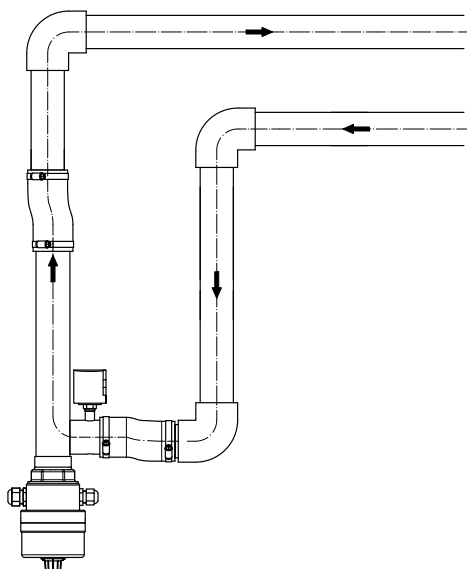
EWT 80-70/-71 встраивается в водяной контур с помощью клеевых фитингов d50 из ПВХ.

	<p><b>ОСТОРОЖНО!</b></p> <p>Возможно повреждение электрического теплообменника.</p> <p>При подключении к водяному контуру необходимо следить за тем, чтобы в электрический теплообменник не попали металлические детали.</p>
	<p><b>ОСТОРОЖНО!</b></p> <p><b>Возможно повреждение электрического теплообменника химикатами.</b></p> <p>Бактерицидные установки следует всегда устанавливать в направлении потока после электрического теплообменника. Расстояние должно быть не менее 1 м, при этом необходимо соблюдать следующую последовательность: сначала контроль жесткости, затем добавление хлора.</p> <p>Если используются химикаты (например, газообразный хлор), необходимо следить за тем, чтобы газы не попадали в электрический теплообменник во время простоя фильтра.</p>

### 2.4.4 Общие указания по установке реле потока

Участок перед реле потока и за ним, где происходит выравнивание потока, должен быть равен как минимум 5-кратному номинальному диаметру.

Реле потока должно устанавливаться только в горизонтальном трубопроводе.

В случае отличающихся систем установки необходимо проконсультироваться с производителем.

Выключатели следует устанавливать только вертикально, отклонение не более 45° (см. рис. 1).

Убедитесь, что в непосредственной близости от реле потока отсутствуют внешние магнитные поля, которые могут повлиять на функционирование устройства (см. рис. 2).

На реле потока имеется стрелка. При установке убедитесь, что она проходит параллельно оси трубы и направлена в направлении потока (см. рис. 3).

Пластиковая накидная гайка G 3/4 должна быть затянута с максимальным моментом затяжки 8 нм.



Abb. 1



Abb. 2



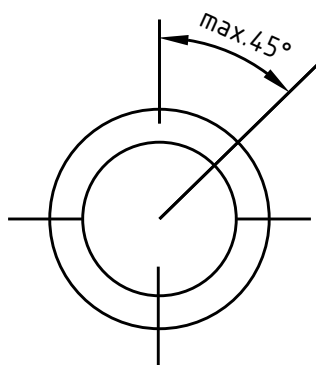

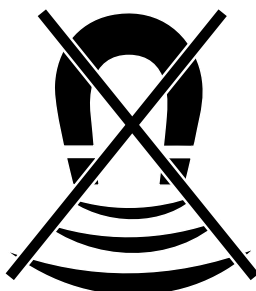

Abb. 3

## 2.5 Электрическое подключение

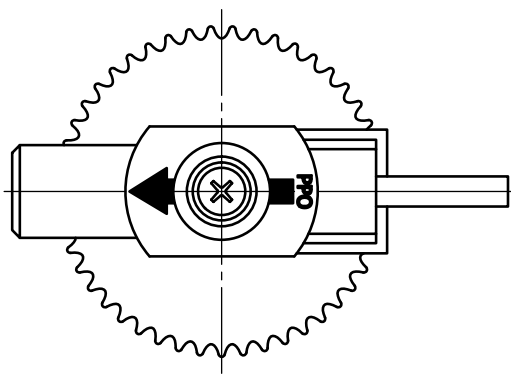
	<p><b>ЭЛЕКТРИЧЕСКОЕ НАПРЯЖЕНИЕ!</b></p> <p>Электрическое подключение должен выполнять только специалист-электрик. При этом необходимо руководствоваться местными нормативными документами, а также предписаниями Союза немецких электротехников VDE 0100. Теплообменник должен быть постоянно подключен к стационарно проложенным проводам с помощью проводника заземления.</p>
	<p><b>ОСТОРОЖНО!</b></p> <p><b>Для защиты электрического теплообменника необходимо использовать не менее двух устройств аварийного отключения.</b></p> <p>На заводе-изготовителе предлагаются следующие комбинации:</p> <ul style="list-style-type: none"> <li>– с регулирующим термостатом;</li> <li>– с регулирующим термостатом и предохранительным ограничителем температуры (STB);</li> <li>– с регулирующим термостатом, STB и реле потока.</li> <li>– с контактором до 12 кВт.</li> </ul> <p>Если на заводе не установлен контактор, для включения нагревательного стержня требуется внешний контактор (например, система управления Behncke для EWT 80-xx).</p>
	<p><b>УКАЗАНИЕ!</b></p> <p>Необходимо убедиться, что электрический теплообменник может включаться только при наличии потока.</p> <p>Электрические соединения должны быть выполнены в соответствии с электрической схемой.</p> <p>В целях обеспечения безопасности необходимо встроить в систему электропитания дифференциальный защитный выключатель (30 мА). Все металлические детали необходимо включить в систему выравнивания потенциалов.</p>

## 2.6 Реле потока

	<p><b>ОСТОРОЖНО!</b></p> <p><b>Опасность для жизни из-за электрического напряжения!</b></p> <p>Перед подключением многожильных проводов соединительного кабеля отключите электрическую систему от источника питания.</p> <p>коричневый/черный = соединения для геркона</p> <p>Геркон встроен в пластиковую гильзу с защитной изоляцией (класс защиты II).</p>
	<p><b>ОСТОРОЖНО!</b></p> <p><b>Опасность для жизни из-за электрического напряжения!</b></p> <p>Ни в коем случае нельзя превышать максимальную нагрузку на электрический контакт, указанную на заводской табличке, так как в противном случае будет поврежден встроенный в коммутационный блок геркон. При индуктивной нагрузке коммутационная способность снижается. Информацию о защитной схеме можно получить у производителя.</p>

### 3 Принцип действия

В электрическом теплообменнике тепло передается воде в бассейне через нагревательный стержень.

Термостат регулирует температуру воды до заданного уровня; диапазон настройки: от 0 до 40 °С.

EWT 80-40/-70: если требуемое рабочее избыточное давление падает ниже 6 кПа (0,06 бар) из-за отсутствия потока, предохранительный клапан ограничения давления отключает электрический теплообменник.

EWT 80-41/-71: если требуемое рабочее избыточное давление падает ниже 36,0 л/мин. из-за отсутствия потока, реле потока отключает EWT.

Опция: Предохранительный термостат

От перегрева защищает предохранительный ограничитель температуры. Он выключает электрический теплообменник при температуре 44 °С.

Путем нажатия кнопки сброса электрический теплообменник можно вернуть в нормальный режим работы после устранения неисправности.

### 4 Ввод в эксплуатацию

Вы изучили руководство по эксплуатации, в частности раздел 1 «Техника безопасности», и поняли его содержание? Это является обязательным условием для ввода электрического теплообменника в эксплуатацию!

- Настройте на термостате нужную температуру воды в бассейне.

Пока не будет достигнуто заданное значение температуры, электрический теплообменник нагревает воду бассейна.

	<p><b>ОСТОРОЖНО!</b></p> <p><b>Возможно повреждение электрического теплообменника.</b></p> <p>В целях обеспечения безопасности работы на трубопроводах и электропроводке должен выполнять только квалифицированный персонал.</p> <p>Запрещается подниматься на электрический теплообменник.</p> <p>Работы по техническому обслуживанию и очистке разрешается выполнять только после закрытия запорной арматуры в водяном контуре!</p> <p>Следует удалить воздух из всего водяного контура, в противном случае возможно повреждение нагревательного элемента.</p>
---	--

### 5 Техническое обслуживание/ремонт

Необходимо еженедельно проверять электрический теплообменник и его соединительные элементы на герметичность и удалять воздух из всего водяного контура.

	<p><b>ОСТОРОЖНО!</b></p> <p><b>Возможно повреждение электрического теплообменника.</b></p> <p>В целях обеспечения безопасности работы на электрическом теплообменнике должен выполнять только квалифицированный персонал.</p> <p>Запрещается подниматься на электрический теплообменник.</p> <p>Работы на патрубках разрешается выполнять только после закрытия запорной арматуры в водяных контурах!</p>
---	---

### 5.1 Хранение электрического теплообменника в зимний период в защищенном от мороза помещении

	<p><b>ОСТОРОЖНО!</b></p> <p>Выполнение работ на техническом оборудовании персоналом, не имеющим соответствующей подготовки, может стать причиной травм и материального ущерба.</p> <p>В случае вывода электрического теплообменника из эксплуатации и его хранения в защищенном от мороза помещении он должен быть полностью заполнен водой либо полностью опорожнен.</p>
---	---

### 5.2 Хранение электрического теплообменника в неотапливаемом помещении в зимний период

	<p><b>ОСТОРОЖНО!</b></p> <p>Надлежащее хранение оборудования в зимний период (без повреждений в результате замерзания) обеспечивается при условии выполнения следующих действий.</p> <ul style="list-style-type: none"> <li>• Закрыть запорную арматуру в водяном контуре. (Запорная арматура должна быть установлена в защищенном от мороза помещении.)</li> <li>• Промыть и опорожнить электрический теплообменник и подключенные трубопроводы вплоть до запорной арматуры.</li> </ul>
---	--

#### 5.2.1 Вертикально расположенный электрический теплообменник

Необходимо полностью слить воду из электрического теплообменника через соответствующую арматуру.

#### 5.2.2 Хранение горизонтально расположенного электрического теплообменника в зимний период

Снимите горизонтально расположенный электрический теплообменник.

Промойте электрический теплообменник для удаления загрязнений и поместите его на хранение в сухое место.

## 6 Неисправности и их устранение

Неисправность	Проверка возможной причины
Отсутствие мощности	<p>Подключен ли электрический теплообменник к электросети? Открыта ли запорная арматура в водяном контуре?</p> <p>Полностью ли заполнен электрический теплообменник водой?</p> <p>Откачан ли воздух из электрического теплообменника?</p>
Электрический теплообменник выполняет нагрев даже при выключенном насосе для циркуляции воды бассейна	<p>Обеспечивается ли достаточный поток воды через электрический теплообменник (см. раздел «Технические характеристики»)?</p> <p>Действует ли блокировка между насосом для воды бассейна и электрическим теплообменником?</p>

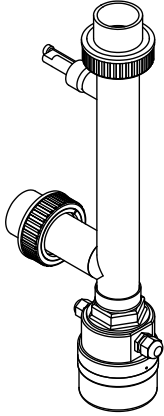

# INSTRUCCIONES DE OPERACIÓN

**EWT-80-40/-41**

**EWT-80-70/-71**

**Intercambiador de calor  
eléctrico**



## **BEHNCKE GmbH**

### **Baviera:**

Michael-Haslbeck Straße 13  
D-85640 Putzbrunn

Tel.: +49 (0)89 / 45 69 17-0  
Fax: +49 (0)89 / 45 69 17-61

### **Sajonia-Anhalt:**

Stötterlinger Straße 36 a  
D-38835 Bühne

Tel.: +49 (0)39421 / 796-0  
Fax: +49 (0)39421 / 796-30

**Correo electrónico:** [info@behncke.com](mailto:info@behncke.com)  
**Internet:** [www.behncke.com](http://www.behncke.com)

## Índice de contenidos

<b>1</b>	<b>Seguridad</b>	<b>1</b>
1.1	Peligros durante el manejo de este intercambiador de calor eléctrico	1
1.2	Indicaciones de seguridad y consejos	1
1.3	Uso conforme a lo previsto	2
1.4	Fuentes de peligro	3
1.5	Medidas de seguridad en el lugar de emplazamiento	3
1.6	Dispositivos de seguridad	4
<b>2</b>	<b>Emplazamiento e instalación</b>	<b>5</b>
2.1	Transportar/Almacenar	5
2.2	Emplazamiento	5
2.3	Instalación	5
2.4	Conexión de agua	6
2.4.1	<i>Disposición de la instalación por encima del nivel del agua</i>	6
2.4.2	<i>Disposición de la instalación por debajo del nivel del agua</i>	7
2.4.3	<i>Conexión del intercambiador de calor eléctrico al circuito de agua de una instalación de filtrado</i>	8
2.4.4	<i>Indicaciones de montaje generales para el interruptor de caudal</i>	8
2.5	Conexión eléctrica	9
2.6	Interruptor de caudal	9
<b>3</b>	<b>Secuencia de funcionamiento</b>	<b>10</b>
<b>4</b>	<b>Puesta en funcionamiento</b>	<b>10</b>
<b>5</b>	<b>Revisiones / mantenimiento</b>	<b>10</b>
5.1	Invernaje del EWT en estancias libres de heladas	11
5.2	Invernaje del EWT en estancias con peligro de heladas	11
5.2.1	<i>Intercambiador de calor eléctrico en disposición vertical</i>	11
5.2.2	<i>Invernaje del EWT en disposición horizontal</i>	11
<b>6</b>	<b>Averías y soluciones</b>	<b>11</b>
<b>7</b>	<b>Representaciones técnicas</b>	<b>Pestaña: Representaciones técnicas</b>
<b>8</b>	<b>Declaración de conformidad</b>	<b>Pestaña: Representaciones técnicas</b>

## 1 Seguridad

### 1.1 Peligros durante el manejo de este intercambiador de calor eléctrico

El intercambiador de calor eléctrico está construido conforme a las últimas novedades técnicas y las reglas técnicas de seguridad reconocidas. A pesar de ello, durante su uso pueden producirse peligros, concretamente

- Lesiones del usuario o
- Terceros o
- Problemas en el intercambiador de calor eléctrico o
- Daños materiales de otro tipo.

Todas las personas que se encarguen de la instalación, la puesta en funcionamiento, el manejo, las revisiones y el mantenimiento del intercambiador de calor eléctrico deberán

- contar con las cualificaciones correspondientes.
- seguir atentamente estas instrucciones de instalación.

Este dispositivo no está destinado al uso por parte de personas (incluyendo niños) con capacidades físicas, sensoriales o mentales limitadas o faltas de experiencia o conocimientos, a menos que las supervise una persona responsable de su seguridad o hayan recibido de esta instrucciones acerca de cómo usar el dispositivo.

El intercambiador de calor eléctrico solo debe utilizarse





- para el uso conforme a lo previsto.
- en perfecto estado técnico de seguridad.

En caso de averías que puedan afectar a la seguridad, deberá recurrirse siempre a un electricista.

¡En las estancias en las que haya equipos eléctricos en funcionamiento debe haber instalado un detector de humos!

Está en juego su seguridad.

### 1.2 Indicaciones de seguridad y consejos

Símbolo	Palabra de señalización / significado
	<b>PELIGRO</b> Le indica una situación peligrosa que conlleva una lesión grave o la muerte si no se evita.
	<b>ADVERTENCIA</b> Le indica una posible situación de peligro que puede conllevar la muerte o lesiones graves si no se evita.
	<b>PRECAUCIÓN</b> Le indica una situación peligrosa que puede conllevar una lesión entre leve y de gravedad media si no se evita.
	<b>NOTA</b> Le indica posibles daños materiales y otra información importante.

El incumplimiento de esta nota puede dar lugar a averías de la instalación o del entorno.

### 1.3 Uso conforme a lo previsto

El intercambiador de calor eléctrico está destinado exclusivamente a calentar el agua de baño con la bomba de circulación o de filtro conectada.

Cualquier otro uso distinto o que vaya más allá de esto se considerará no conforme a lo previsto.

El fabricante, BEHNCKE® GmbH, no se hace responsable de los daños que se produzcan.

Solo será posible otro uso previo acuerdo y aprobación por parte del fabricante.



#### **¡NOTA!**

En el uso conforme a lo previsto se incluye también

- el cumplimiento de todas las indicaciones de las instrucciones de instalación y
- la realización de los trabajos de inspección y revisión

No debe superarse la sobrepresión de operación máxima permitida de 300 kPa (3 bar).

No se debe permanecer por debajo de la sobrepresión de operación mínima necesaria de 10 kPa (0,1 bar).

El rendimiento mínimo es de 1000 l/h.

**Solo puede utilizarse agua con los siguientes valores:**

#### **EWT 80-40/-41, 80-70/-71**

Contenido de cloruro      máx. 500 mg/l

Cloro libre                    máx. 1,3 mg/l

pH                                6,8 - 8,2



Índice de Langelier        -0,3 – +0,3

**La resistencia específica del agua no debe ser inferior a  $\leq 1100 \Omega \text{ cm}$  a 15°C.**

Se prohíben las reestructuraciones y modificaciones en el intercambiador de calor eléctrico por motivos de seguridad.

Los trabajos de revisión y reparación en las tuberías y la instalación eléctrica solo deben ser llevados a cabo por personal técnico, por motivos de seguridad.



## 1.4 Fuentes de peligro

	<p><b>¡PRECAUCIÓN!</b></p> <p><b>El intercambiador de calor eléctrico puede sufrir daños.</b></p> <p>En caso de que se supere la sobrepresión de operación máx. de 300 kPa (3,0 bar), el intercambiador de calor eléctrico puede perder su estanqueidad.</p>
	<p><b>¡PRECAUCIÓN!</b></p> <p><b>Existe peligro de quemaduras.</b></p> <p>Las conexiones y el intercambiador de calor eléctrico pueden alcanzar temperaturas de hasta 100°C.</p> <p>En caso de que el caudal de agua no sea suficiente (&lt; 1000 l/h), puede darse un fuerte sobrecalentamiento del intercambiador de calor eléctrico.</p> <p>En principio, se recomienda la instalación de un monitor de caudal como dispositivo de seguridad adicional.</p>
	<p><b>¡PRECAUCIÓN!</b></p> <p><b>El intercambiador de calor eléctrico puede sufrir daños.</b></p> <p>Existe riesgo de corrosión por contacto debido al goteo de agua sobre la capa exterior o en caso de que se sumerjan piezas metálicas en el intercambiador de calor eléctrico.</p>

## 1.5 Medidas de seguridad en el lugar de emplazamiento

El intercambiador de calor eléctrico debe montarse en una estancia segura frente a heladas con un soporte de acero inoxidable o de plástico.

Asegúrese de que no se supere la presión de operación máxima de 300 kPa (3,0 bar).

	<p><b>¡PRECAUCIÓN!</b></p> <p>El intercambiador de calor eléctrico o el entorno pueden sufrir daños.</p> <p>Durante la operación de la piscina, compruebe al menos una vez a la semana que el intercambiador de calor eléctrico y sus conexiones no presenten fugas ni daños visibles externos.</p>
	<p><b>¡PRECAUCIÓN!</b></p> <p><b>Existe peligro de incendio.</b></p> <p>En caso de que el caudal de agua no sea suficiente (&lt; 1000 l/h), puede darse un fuerte sobrecalentamiento del intercambiador de calor eléctrico.</p> <p>No guarde materiales combustibles en el entorno.</p> <p>En principio, se recomienda la instalación de un monitor de caudal como dispositivo de seguridad adicional.</p> <p>Además, impide que se queme la resistencia de calefacción en caso de parada del agua.</p>

**¡PRECAUCIÓN!****El intercambiador de calor eléctrico puede sufrir daños.**

El intercambiador de calor eléctrico solo podrá ponerse en funcionamiento cuando se asegure el suministro constante de agua durante la operación del intercambiador de calor eléctrico. El rendimiento de agua deberá ser como mínimo de 1000 l/h.

**1.6 Dispositivos de seguridad**

El letrero de advertencia en el intercambiador de calor eléctrico indica los peligros por la corriente eléctrica.

El intercambiador de calor eléctrico está equipado con un limitador de presión de seguridad.

El limitador de presión de seguridad sirve de seguro de falta de agua (véase EWT 80-40 o -70).

**¡PRECAUCIÓN!**

El intercambiador de calor eléctrico debe estar protegido por al menos dos dispositivos de desconexión de seguridad.

Se ofrecen de fábrica las siguientes combinaciones

- con un limitador de temperatura de seguridad
- con un termostato de regulación y un limitador de temperatura de seguridad (STB)
- con un termostato de regulación, un STB y un interruptor de caudal
- con un contactor de hasta 12 kW.

Si no hay ningún contactor instalado de fábrica, se necesitará un contactor externo para la conexión de la varilla de calefacción (ej. control Behncke ® para EWT 80-xx).

Control con un contactor:                    3–12 kW      N.º art. 304 006 12  
     15–18 kW      N.º art. 304 006 18

Control con un segundo contactor integrado para la desconexión de seguridad con luz de control (recomendada encarecidamente) para el EWT 80-41/-71 con regulador y termostato de seguridad:  
     3–12 kW      N.º art. 304 007 12  
     15–18 kW      N.º art. 304 007 18

– ¡Armario de conexiones no incluido en el volumen de suministro! –

Los dispositivos de seguridad desconectan el intercambiador de calor eléctrico en caso de que se alcancen valores no permitidos.

## 2 Emplazamiento e instalación

### 2.1 Transportar/Almacenar

Transporte el intercambiador de calor eléctrico solo cuando esté vacío.



Almacene el intercambiador de calor eléctrico enjuagado y vaciado únicamente en interiores con una atmósfera no agresiva.

### 2.2 Emplazamiento

Coloque el intercambiador de calor eléctrico únicamente en estancias libres de heladas y secas con una atmósfera no agresiva.

Las gotas de agua pueden causar daños en el intercambiador de calor eléctrico.

Garantice un fácil acceso para el montaje y el desmontaje.

	<p><b>¡PRECAUCIÓN!</b></p> <p>Para el intercambiador de calor eléctrico, es imprescindible cumplir con los siguientes valores del agua.</p> <p><b>EWT 80-40/-41, 80-70/-71</b></p> <table><tbody><tr><td>Contenido de cloruro</td><td>máx. 500 mg/l</td></tr><tr><td>Cloro libre</td><td>máx. 1,3 mg/l</td></tr><tr><td>pH</td><td>6,8 - 8,2</td></tr><tr><td>Índice de Langelier</td><td>-0,3 – +0,3</td></tr><tr><td>Rendimiento del agua</td><td>mín. 1000 l/h</td></tr><tr><td>Presión de operación mín.</td><td>10 kPa (0,1 bar)</td></tr><tr><td>Presión de operación máx.</td><td>300 kPa (3,0 bar)</td></tr></tbody></table>	Contenido de cloruro	máx. 500 mg/l	Cloro libre	máx. 1,3 mg/l	pH	6,8 - 8,2	Índice de Langelier	-0,3 – +0,3	Rendimiento del agua	mín. 1000 l/h	Presión de operación mín.	10 kPa (0,1 bar)	Presión de operación máx.	300 kPa (3,0 bar)
Contenido de cloruro	máx. 500 mg/l														
Cloro libre	máx. 1,3 mg/l														
pH	6,8 - 8,2														
Índice de Langelier	-0,3 – +0,3														
Rendimiento del agua	mín. 1000 l/h														
Presión de operación mín.	10 kPa (0,1 bar)														
Presión de operación máx.	300 kPa (3,0 bar)														
	<p><b>¡PRECAUCIÓN!</b></p> <p>Si fallan los dispositivos de seguridad, existe peligro de incendios.</p> <p>El sobrecalentamiento del intercambiador de calor eléctrico puede provocar un incendio.</p> <p>Debe evitarse que el intercambiador de calor eléctrico marche en vacío.</p> <p>No guarde materiales combustibles en el entorno.</p>														

### 2.3 Instalación

Antes de la instalación, deberá comprobar que el intercambiador de calor eléctrico no presente daños visibles.

El intercambiador de calor eléctrico puede instalarse horizontal o verticalmente por encima o por debajo del nivel del agua.

En caso de instalación a más o menos de 0,50 m del nivel del agua, el interruptor de presión de seguridad (seguro de falta de agua) pierde su eficacia.

En este caso, en lugar del interruptor de presión será necesario un interruptor de caudal Behncke ®. (véase EWT 80-41/-71)

## 2.4 Conexión de agua

### 2.4.1 Disposición de la instalación por encima del nivel del agua



Figura: Montaje horizontal (EWT 80-40/-70)



Figura: Montaje horizontal (EWT 80-41/-71)

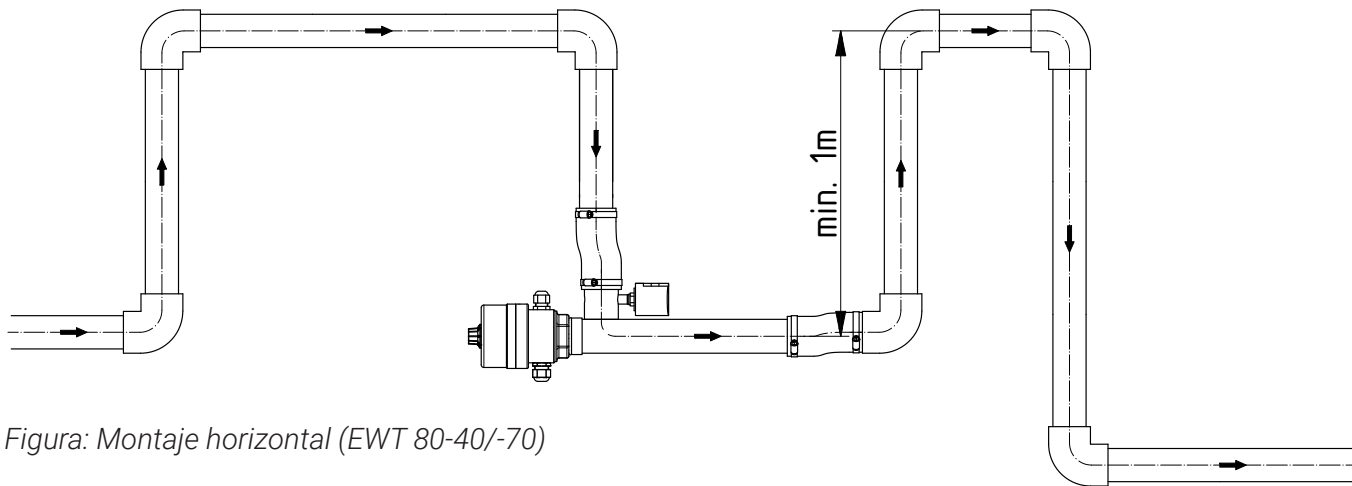

Figura: Montaje vertical (EWT 80-40/-70)

### 2.4.2 Disposición de la instalación por debajo del nivel del agua

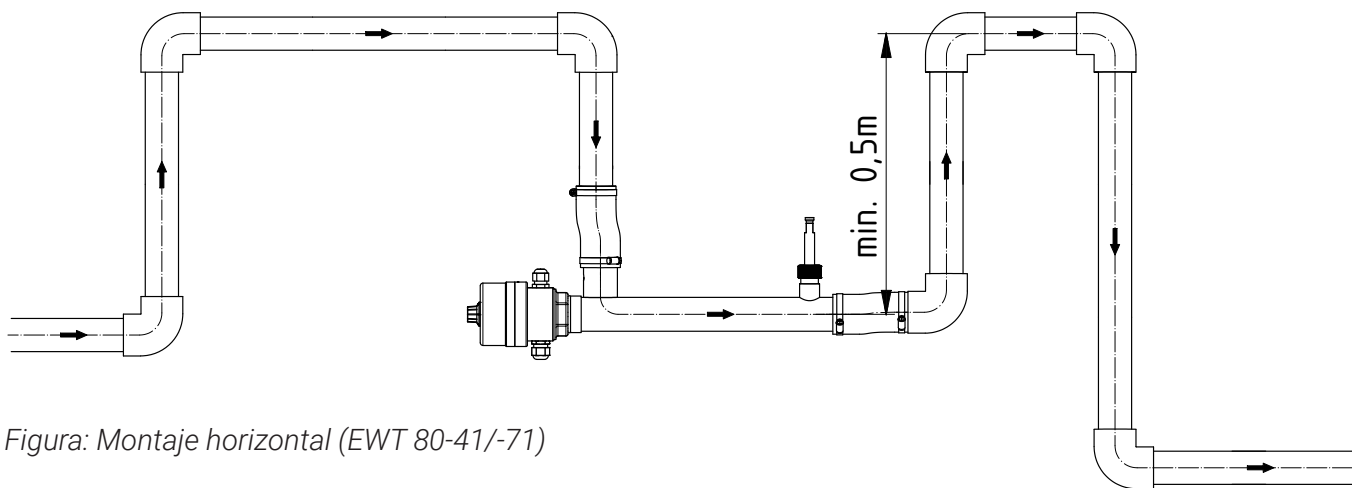

Figura: Montaje horizontal (EWT 80-40/-70)

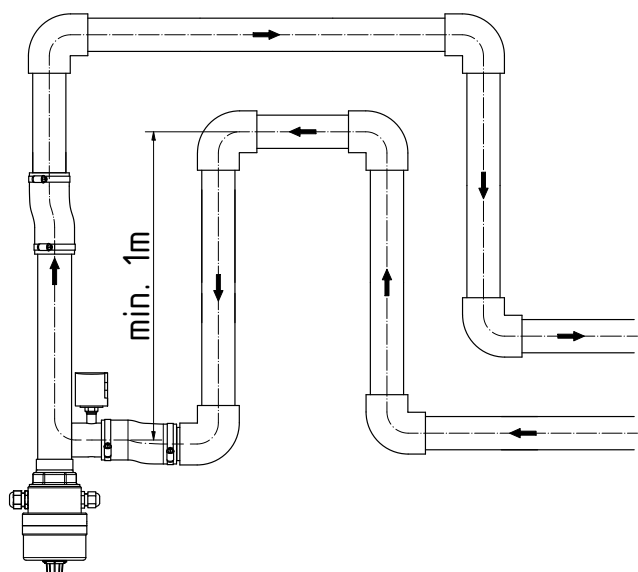

Figura: Montaje horizontal (EWT 80-41/-71)



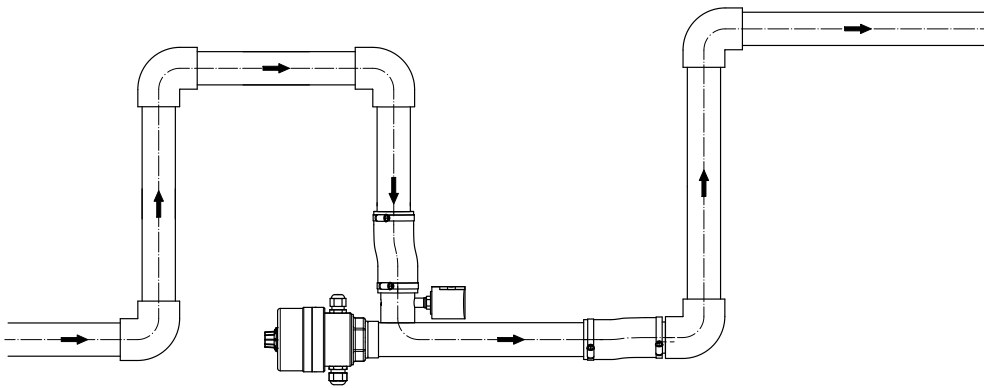

Figura: Montaje vertical (EWT 80-40/-70)

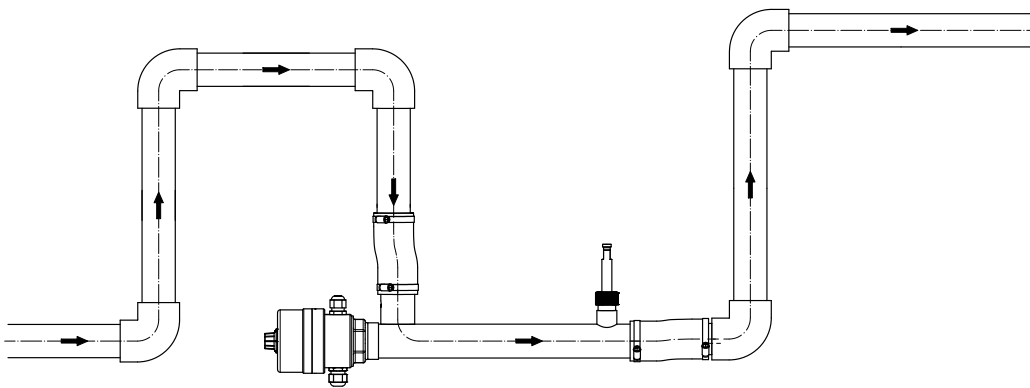
### 2.4.3 Conexión del intercambiador de calor eléctrico al circuito de agua de una instalación de filtrado

Monte el intercambiador de calor eléctrico en el conducto de presión (a la piscina) después de la bomba y el filtro.

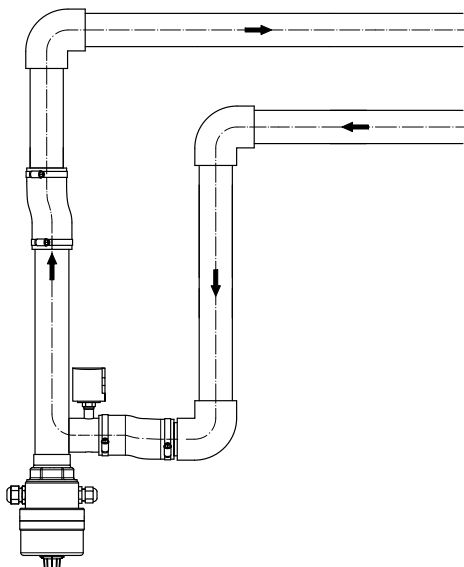
El EWT 80-40/-41 se integra en el circuito de agua a través de la rosca interior 1 1/2" o tuberías unidas con bornes.

El EWT 80-70/-71 se integra en el circuito de agua con atornillamientos adhesivos de PVC d50.

	<p><b>¡PRECAUCIÓN!</b></p> <p>El intercambiador de calor eléctrico puede sufrir daños.</p> <p>Al conectarlo al circuito de agua, debe prestarse atención a que no se introduzca ninguna pieza metálica en el intercambiador de calor eléctrico.</p>
	<p><b>¡PRECAUCIÓN!</b></p> <p><b>El intercambiador de calor eléctrico puede sufrir daños por productos químicos.</b></p> <p>Los dispositivos de desinfección deben instalarse siempre en la dirección del caudal, después del intercambiador de calor eléctrico. La distancia debe ser de al menos 1 m y el orden es: primero la regulación de la dureza, después la inyección de cloro.</p> <p>Si se utilizan productos químicos (por ejemplo, gas de cloro), no deben entrar gases en el intercambiador de calor eléctrico durante los tiempos de parada del filtro.</p>

### 2.4.4 Indicaciones de montaje generales para el interruptor de caudal

El recorrido de relajación debe ser de al menos 5 x DN delante y detrás del interruptor de control de caudal.

El interruptor de control de caudal solo puede montarse en un conducto en horizontal.

En caso de que las instalaciones de montaje sean diferentes, deberá consultar al fabricante.

Solo debe montar los interruptores en vertical, desviación máx. 45° (véase la Fig. 1).

Asegúrese de que no haya campos magnéticos ajenos en las inmediaciones del interruptor de control de caudal que puedan afectar al funcionamiento del dispositivo (véase la Fig. 2).

En el interruptor de control de caudal hay una flecha. Al realizar el montaje, preste atención a que esta se encuentre siempre en paralelo con el eje del tubo y apuntando a la dirección del caudal (véase la Fig. 3).

La tuerca de racor G 3/4 de plástico debe apretarse con un par de apriete máx. de 8 Nm.



Abb. 1



Abb. 2



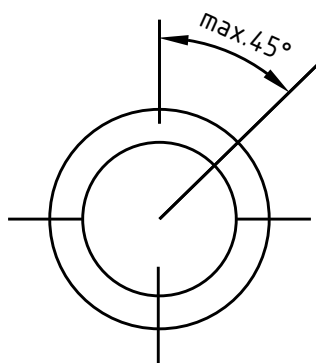

Abb. 3

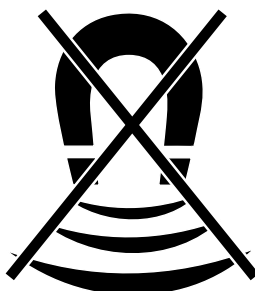
## 2.5 Conexión eléctrica

	<p><b>¡TENSIÓN ELÉCTRICA!</b></p> <p>La conexión eléctrica debe ser realizada únicamente por un electricista. Deben considerarse las disposiciones locales y la VDE 0100. El intercambiador de calor deberá conectarse de forma permanente a conductos tendidos fijos con un conductor de protección.</p>
	<p><b>¡PRECAUCIÓN!</b></p> <p><b>El intercambiador de calor eléctrico debe estar protegido por al menos dos dispositivos de desconexión de seguridad.</b></p> <p>Se ofrecen de fábrica las siguientes combinaciones</p> <ul style="list-style-type: none"> <li>- con un termostato de regulación</li> <li>- con un termostato de regulación y un limitador de temperatura de seguridad (STB)</li> <li>- con un termostato de regulación, un STB y un interruptor de caudal.</li> <li>- con un contactor de hasta 12 kW.</li> </ul> <p>Si no hay ningún contactor instalado de fábrica, se necesitará un contactor externo para la conexión de la varilla de calefacción (ej. control Behncke para EWT 80-xx).</p>
	<p><b>¡NOTA!</b></p> <p>Debe asegurarse que el intercambiador de calor eléctrico solo pueda conectarse con el caudal asegurado.</p> <p>Las conexiones eléctricas deben llevarse a cabo de acuerdo con el esquema de conexiones.</p> <p>Por motivos de seguridad, deberá integrarse un interruptor de protección FI (30 mA) en el suministro de tensión. Todas las piezas de metal deben integrarse en el equipotencial.</p>

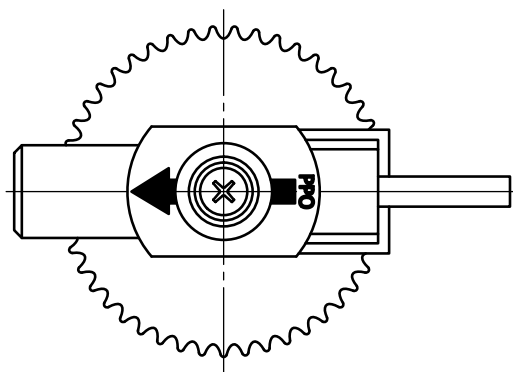
## 2.6 Interruptor de caudal

	<p><b>¡PRECAUCIÓN!</b></p> <p><b>¡Peligro de muerte por tensión eléctrica!</b></p> <p>Desconecte la tensión de la instalación eléctrica antes de conectar los hilos del cable de conexión.</p> <p>marrón/negro = Conexiones para el contacto Reed</p> <p>El contacto Reed está integrado en un casquillo de plástico con aislamiento de protección (clase de protección II).</p>
	<p><b>¡PRECAUCIÓN!</b></p> <p><b>¡Peligro de muerte por tensión eléctrica!</b></p> <p>La carga de contacto eléctrica máx. indicada en la placa de características no puede superarse nunca, ya que de lo contrario se dañará el contacto Reed integrado en la unidad de conexión. En el caso de las cargas inductivas, se reduce la capacidad de conmutación. Puede consultar los datos sobre las conexiones de protección a la sede del fabricante.</p>

### 3 Secuencia de funcionamiento

En el intercambiador de calor eléctrico, se transmite calor al agua de baño a través de la varilla de calefacción.

El termostato regula la temperatura del agua al nivel ajustado, rango de ajuste: 0 a 40°C.

EWT 80-40/-70: Si la sobrepresión de operación necesaria se reduce por falta de caudal por debajo de 6 kPa (0,06 bar), el limitador de presión de seguridad desconectará el intercambiador de calor eléctrico.

EWT 80-41/-71: Si la sobrepresión de operación necesaria se reduce por falta de caudal por debajo de los 36,0 l/min, el interruptor de caudal desconectará el EWT.

Opcional: Termostato de seguridad

Protege del sobrecalentamiento el limitador de temperatura de seguridad. Este desconecta el intercambiador de calor eléctrico a una temperatura de 44°C.

Pulsando el botón de eliminación de averías, es posible volver a poner el intercambiador de calor eléctrico en un estado listo para la operación normal una vez solucionada una avería.

### 4 Puesta en funcionamiento

¿Ha leído y comprendido estas instrucciones de operación, en especial, el capítulo 1 Seguridad?

¡No puede poner el intercambiador de calor eléctrico en funcionamiento antes!

- Ajuste la temperatura del agua de baño deseada en el termostato.

El intercambiador de calor eléctrico calentará el agua de baño mientras no se haya alcanzado la temperatura ajustada.

	<p><b>¡PRECAUCIÓN!</b></p> <p><b>El intercambiador de calor eléctrico puede sufrir daños.</b></p> <p>Los trabajos en las tuberías y la instalación eléctrica solo deben ser llevados a cabo por personal técnico, por motivos de seguridad.</p> <p>No se suba al intercambiador de calor eléctrico.</p> <p>¡Lleve a cabo los trabajos de revisión y limpieza únicamente con los dispositivos de cierre cerrados con el circuito de agua!</p> <p>Desaíree todo el circuito de agua, de lo contrario, el elemento de calefacción puede sufrir daños.</p>
---	--

### 5 Revisiones / mantenimiento

Verifique la estanqueidad del intercambiador de calor eléctrico y las conexiones una vez por semana y desaíree todo el circuito de agua.

	<p><b>¡PRECAUCIÓN!</b></p> <p><b>El intercambiador de calor eléctrico puede sufrir daños.</b></p> <p>Por motivos de seguridad, los trabajos en el intercambiador de calor eléctrico deberán ser llevados a cabo únicamente por personal técnico.</p> <p>No se suba al intercambiador de calor eléctrico.</p> <p>¡Los trabajos en las tuberías solo pueden ser llevados a cabo con los dispositivos de cierre cerrados en los circuitos de agua!</p>
---	---

## 5.1 Invernaje del EWT en estancias libres de heladas

	<p><b>¡PRECAUCIÓN!</b></p> <p>Las intervenciones en instalaciones técnicas por parte de personas no expertas pueden dar lugar a lesiones y daños materiales.</p> <p>En caso de parada en estancias libres de heladas, el intercambiador de calor eléctrico deberá estar completamente lleno de agua o completamente vaciado.</p>
---	--

## 5.2 Invernaje del EWT en estancias con peligro de heladas

	<p><b>¡PRECAUCIÓN!</b></p> <p>Es posible invernaje correctamente sin que se produzcan daños por heladas si se siguen los siguientes pasos.</p> <ul style="list-style-type: none"> <li>• Cierre los dispositivos de cierre del circuito de agua. (Los dispositivos de cierre deben estar instalados en estancias libres de heladas).</li> <li>• Lave y vacíe el intercambiador de calor eléctrico y las tuberías anexas hasta llegar a los dispositivos de cierre.</li> </ul>
---	--

### 5.2.1 Intercambiador de calor eléctrico en disposición vertical

Vacíe completamente el intercambiador de calor eléctrico a través de las válvulas de drenaje.

### 5.2.2 Invernaje del EWT en disposición horizontal

Desmonte el intercambiador de calor eléctrico en disposición horizontal.

Lave el intercambiador de calor eléctrico para eliminar la suciedad y guárdelo en un lugar seco.

## 6 Averías y soluciones

Error	Verificación de la posible causa
No hay potencia	<p>¿Tiene conexión eléctrica el intercambiador de calor eléctrico? ¿Están abiertos los dispositivos de cierre en el circuito de agua?</p> <p>¿Está el intercambiador de calor eléctrico completamente lleno de agua?</p> <p>¿Se ha ventilado el intercambiador de calor eléctrico?</p>
El intercambiador de calor eléctrico se sigue calentando a pesar de que la bomba de circulación del agua de baño está desconectada	<p>¿Tiene el intercambiador de calor eléctrico un suficiente caudal de agua (véase Datos técnicos)?</p> <p>¿Está activo el bloqueo entre la bomba del agua de baño y el intercambiador de calor eléctrico?</p>

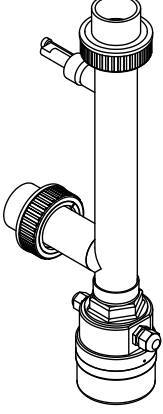

# İŞLETME TALİMATI

**EWT-80-40/-41**

**EWT-80-70/-71**

**Elektro ısı eşanjörü**



**BEHNCKE GmbH**

**Bavyera:**

Michael-Haslbeck Straße 13  
D-85640 Putzbrunn

Telefon: +49 (0)89 / 45 69 17-0

Faks: +49 (0)89 / 45 69 17-61

**Saksonya-Anhalt:**

Stötterlinger Straße 36 a  
D-38835 Bühne

Telefon: +49 (0)39421 / 796-0

Faks: +49 (0)39421 / 796-30

**E-posta:** [info@behncke.com](mailto:info@behncke.com)

**Internet:** [www.behncke.com](http://www.behncke.com)

# İçindekiler

<b>1</b>	<b>Güvenlik</b>	<b>1</b>
1.1	Bu ısı eşanjörü kullanımındaki tehlikeler	1
1.2	Güvenlik hatırlatmaları ve ipuçları	1
1.3	Amacına uygun kullanım	2
1.4	Tehlike kaynakları	3
1.5	Kurulum yerinde güvenlik önlemleri	3
1.6	Güvenlik tertibatları	4
<b>2</b>	<b>Yerleşim ve kurulum</b>	<b>5</b>
2.1	Taşıma/Depolama	5
2.2	Yerleşim	5
2.3	Kurulum	5
2.4	Su bağlantısı	6
2.4.1	<i>Su seviyesi üzerindeki kurulum düzenlemesi</i>	6
2.4.2	<i>Su seviyesi altındaki kurulum düzenlemesi</i>	7
2.4.3	<i>Elektro ısı eşanjörünün bir filtre sisteminin su devrine bağlantısı</i>	8
2.4.4	<i>Akış şalteri için genel montaj hatırlatmaları</i>	8
2.5	Elektrik bağlantısı	9
2.6	Akış şalteri	9
<b>3</b>	<b>Fonksiyon akışı</b>	<b>10</b>
<b>4</b>	<b>Devreye alma</b>	<b>10</b>
<b>5</b>	<b>Bakım / onarım</b>	<b>10</b>
5.1	EWT'nin kış mevsiminde donlanma olmayan odalarda saklanması	11
5.2	EWT'nin kış mevsiminde donlanma tehlikesi olan odalarda saklanması	11
5.2.1	<i>Dikey düzende elektro ısı eşanjörü</i>	11
5.2.2	<i>EWT'nin kış mevsiminde yatay düzende saklanması</i>	11
<b>6</b>	<b>Arızalar ve çözümler</b>	<b>11</b>
<b>7</b>	<b>Teknik resimler</b>	<b>Sekme: Teknik resimler</b>
<b>8</b>	<b>Uygunluk beyanı</b>	<b>Sekme: Teknik resimler</b>

## 1 Güvenlik

### 1.1 Bu ısı eşanjörü kullanımındaki tehlikeler

Elektro ısı eşanjörü teknolojinin güncel durumuna ve güvenlik açısından önemli yaygın kurallara göre üretilmiştir. Yine de kullanımda aşağıdaki tehlikeler meydana gelebilir:

- Operatörün veya
- üçüncü tarafların yaralanması ya da
- elektro ısı eşanjöründe kısıtlamalar veya
- diğer maddi değerlerde hasarlar.

Elektro ısı eşanjörünün kurulumu, devreye alma işlemi, kullanımı, bakımı ve onarımı ile ilgilenen tüm kişiler şu özelliklere sahip olmalıdır:

- İlgili niteliğe sahip olmalıdır.
- Bu işletme talimatını dikkate almalıdır.

Bu cihaz fiziksel, duysal veya zihinsel yetenekleri kısıtlı olan kişiler (çocuklar dahil) tarafından veya tecrübe eksikliği ve/ya da bilgi eksikliği sebebiyle güvenliklerinden sorumlu bir kişinin gözetimi altında bulunmadıkları veya cihazın kullanım şekline dair talimat almadıkları takdirde kullanılması için tasarlanmamıştır.

Elektro ısı eşanjörü yalnızca şu durumlarda kullanılabilir:





- Amacına uygun kullanım için.
- Güvenlik açısından kusursuz durumda olduğunda.

Güvenliği etkileyebilecek arızalar durumunda genel olarak bir elektrik teknisyenine başvurulmalıdır.

Elektrikli cihazların çalıştırıldığı odalarda bir duman dedektörü kurulmuş olmalıdır!

Söz konusu olan güvenliğinizdir.

### 1.2 Güvenlik hatırlatmaları ve ipuçları

Sembol	İşaret sözcüğü / anlamı
	<b>TEHLİKE</b> Önlenmediğinde ciddi bir yaralanmaya veya ölüme neden olabilecek tehlikeli bir duruma dikkat çeker.
	<b>UYARI</b> Önlenmediğinde ölüme veya ciddi yaralanmaya neden olabilecek tehlikeli bir duruma dikkat çeker.
	<b>DİKKAT</b> Önlenmediğinde hafif ila orta dereceli bir yaralanmaya neden olabilecek tehlikeli bir duruma dikkat çeker.
	<b>HATIRLATMA</b> Olası maddi hasarlara ve diğer önemli bilgilere dikkat çeker.

Bu hatırlatma bilgisi dikkate alınmadığında sistemde veya ortamda arızalar meydana gelebilir.

### 1.3 Amacına uygun kullanım

Elektro ısı eşanjörü sadece sirkülasyon/filtre pompası açıkken havuz suyunun ısıtılması içindir. Başka bir kullanım veya bunun dışında bir kullanım amacına uygun değildir. Bundan dolayı oluşacak hasarlardan üretici BEHNCKE® GmbH sorumlu değildir.

Başka bir kullanım sadece üretici ile mutabık kalınarak ve üretici onayı ile mümkündür.



#### HATIRLATMA!

Amacına uygun kullanım arasında şunlar yer alır:

- Tüm kurulum talimatları hatırlatmalarının dikkate alınması ve
- denetim ve bakım çalışmalarına uyulması

İzin verilen maksimum aşırı çalışma basıncı 300 kPa (3 bar) aşılmamalıdır.

Gerekli olan minimum aşırı çalışma basıncı 10 kPa (0,1 bar) altına düşülmemelidir.

Asgari debi 1000 l/sa'tir.

**Sadece aşağıdaki değerlere sahip su kullanılabilir:**

#### EWT 80-40/-41, 80-70/-71



Klorit oranı	maks. 500 mg/l
serbest klor	maks. 1,3 mg/l
pH	6,8 - 8,2
Langelier endeksi	-0,3 – +0,3

**Özel su direnci, 15°C'de  $\leq 1100 \Omega$  cm altında olmamalıdır.**

Elektro ısı eşanjöründe tadilatlar ve değişiklikler güvenlik nedenlerinden dolayı yasaktır.

Boru hatlarında ve elektrik tesisatındaki bakım ve onarım çalışmaları güvenlik nedenlerinden dolayı sadece uzman personel tarafından gerçekleştirilebilir.



## 1.4 Tehlike kaynakları

	<p><b>DİKKAT!</b></p> <p><b>Elektro ısı eşanjörü hasar görebilir.</b></p> <p>300 kPa (3,0 bar)'lık maks. aşırı çalışma basıncı aşıldığında elektro ısı eşanjörü sızıntı yapabilir.</p>
	<p><b>DİKKAT!</b></p> <p><b>Yanma tehlikesi söz konusudur.</b></p> <p>Bağlantılar ve elektro ısı eşanjörü 100°C'a kadar sıcaklıklara gelebilir.</p> <p>Su debisi (&lt; 1000 l/sa) yetersiz olduğunda elektro ısı eşanjörünün yüksek derecede aşırı ısınması mümkündür.</p> <p>Diğer güvenlik tertibatı olarak bir akış kontrol cihazının monte edilmesi önemle tavsiye edilir.</p>
	<p><b>DİKKAT!</b></p> <p><b>Elektro ısı eşanjörü hasar görebilir.</b></p> <p>Dış kabuğa damlayan su veya elektro ısı eşanjörüne metal parçaların sürüklenmesi sonucunda temas korozyonu tehlikesi vardır.</p>

## 1.5 Kurulum yerinde güvenlik önlemleri

Elektro ısı eşanjörü dona karşı korunmuş bir odada bir paslanmaz çelik veya plastik tutucu ile monte edilmelidir.

300 kPa (3,0 bar)'lık maksimum çalışma basıncının aşılmadığından emin olun.

	<p><b>DİKKAT!</b></p> <p>Elektro ısı eşanjörü veya ortam hasar görebilir.</p> <p>Havuzu çalıştırdığınızda haftada en az bir kez elektro ısı eşanjörünü ve bağlantılarını sızdırmazlık ve dıştan görünen hasarlar için kontrol edin.</p>
	<p><b>DİKKAT!</b></p> <p><b>Yangın tehlikesi var.</b></p> <p>Su debisi (&lt; 1000 l/sa) yetersiz olduğunda elektro ısı eşanjörünün yüksek derecede aşırı ısınması mümkündür.</p> <p>Ortamda yanıcı materyaller depolamayın.</p> <p>Diğer güvenlik tertibatı olarak bir akış kontrol cihazının monte edilmesi önemle tavsiye edilir.</p> <p>Bu, ayrıca ısıtma rezistansının su durduğunda yanmasını da önler.</p>

**DİKKAT!****Elektro ısı eşanjörü hasar görebilir.**

Elektro ısı eşanjörü sadece, çalışma sırasında elektro ısı eşanjörünün sürekli su ile beslendiğinden emin olduğunda çalıştırılabilir. Su debisi en az 1000 l/sa olmalıdır.

**1.6 Güvenlik tertibatları**

Elektro ısı eşanjöründeki uyarı levhası elektrik akım tehlikelerine işaret eder.

Elektro ısı eşanjörü bir emniyet basınç sınırlandırıcısıyla donatılmıştır.

Emniyet basınç sınırlandırıcısı, su sıkıntısı emniyeti olarak işlev görür (bkz. EWT 80-40 veya -70).

**DİKKAT!**

Elektro ısı eşanjörü en az iki emniyet anahtarıyla korunmalıdır.

Fabrikadan aşağıdaki kombinasyonlar sunulmaktadır

- bir emniyet sıcaklık sınırlandırıcısı ile
- bir ayar termostadı ve bir emniyet sıcaklık sınırlandırıcısı (TD) ile
- bir ayar termostadı, bir STB ve bir akış şalteri ile
- 12 kW'a kadar bir kontaktör ile.

Fabrikadan bir kontaktör kurulmamış ise, ısıtma çubuğunun anahtarlanması için harici bir kontaktör gereklidir (örn. EWT 80-xx için Behncke ® kumandası).

Bir kontaktörü olan kumanda:	3–12 kW	Ürün no. 304 006 12
	15–18 kW	Ürün no. 304 006 18

Ayar ve emniyet termostadı ile EWT 80-41/-71 için kontrol lambalı emniyet kapatmasına ait monteli ikinci kontaktörü (önemle tavsiye edilir) olan kumanda:

3–12 kW	Ürün no. 304 007 12
15–18 kW	Ürün no. 304 007 18

– Teslimat kapsamında şalter kutusu bulunmaz! –

Emniyet tertibatları, izin verilmeyen değerlere ulaşıldığında elektro ısı eşanjörünü kapatır.

## 2 Yerleşim ve kurulum

### 2.1 Taşıma/Depolama

Elektro ısı eşanjörünü sadece boşaltılmış bir vaziyette taşıyın.



Durulanmış ve boşaltılmış elektro ısı eşanjörünü sadece agresif atmosferi olmayan iç mekanlarda depolayın.

### 2.2 Yerleşim

Elektro ısı eşanjörünü sadece agresif atmosferi olmayan, dona karşı korunmuş kuru odalara yerleştirin.

Damlayan su elektro ısı eşanjörüne hasar verebilir.

Montaj ve söküm işleri için kolay erişilebilirliği sağlayın.

	<p><b>DİKKAT!</b></p> <p>Elektro ısı eşanjörü için aşağıdaki su değerlerine mutlaka uyulmalıdır.</p> <p><b>EWT 80-40/-41, 80-70/-71</b></p> <table><tr><td>Klorit oranı</td><td>maks. 500 mg/l</td></tr><tr><td>serbest klor</td><td>maks. 1,3 mg/l</td></tr><tr><td>pH</td><td>6,8 - 8,2</td></tr><tr><td>Langelier endeksi</td><td>-0,3 – +0,3</td></tr><tr><td>Su debisi</td><td>min. 1000 l/h</td></tr><tr><td>min. çalışma basıncı</td><td>10 kPa (0,1 bar)</td></tr><tr><td>maks. çalışma basıncı</td><td>300 kPa (3,0 bar)</td></tr></table>	Klorit oranı	maks. 500 mg/l	serbest klor	maks. 1,3 mg/l	pH	6,8 - 8,2	Langelier endeksi	-0,3 – +0,3	Su debisi	min. 1000 l/h	min. çalışma basıncı	10 kPa (0,1 bar)	maks. çalışma basıncı	300 kPa (3,0 bar)
Klorit oranı	maks. 500 mg/l														
serbest klor	maks. 1,3 mg/l														
pH	6,8 - 8,2														
Langelier endeksi	-0,3 – +0,3														
Su debisi	min. 1000 l/h														
min. çalışma basıncı	10 kPa (0,1 bar)														
maks. çalışma basıncı	300 kPa (3,0 bar)														
	<p><b>DİKKAT!</b></p> <p>Emniyet tertibatlarının arızası durumunda yangın tehlikesi vardır.</p> <p>Elektro ısı eşanjörünün aşırı ısınması bir yangına yol açabilir.</p> <p>Elektro ısı eşanjörünün işletim sırasında boşta çalışması önlenmelidir.</p> <p>Ortamda yanıcı materyaller depolamayın.</p>														

### 2.3 Kurulum

Kurulumdan önce elektro ısı eşanjöründe gözle görünür hasarların olup olmadığı kontrol edilmelidir.

Elektro ısı eşanjörü, su seviyesinin üstünde veya altında yatay olarak veya dikey olarak kurulabilir.

Su seviyesinin 0,50 m üstünde veya altında olan kurulumda emniyet basınç şalteri (su sıkıntısı emniyeti) etkinliğini kaybeder.

Bu durumda basınç şalterinin yerine bir Behncke ® akış şalteri mutlaka gereklidir.

(bkz. EWT 80-41/-71)

## 2.4 Su bağlantısı

### 2.4.1 Su seviyesi üzerindeki kurulum düzenlemesi

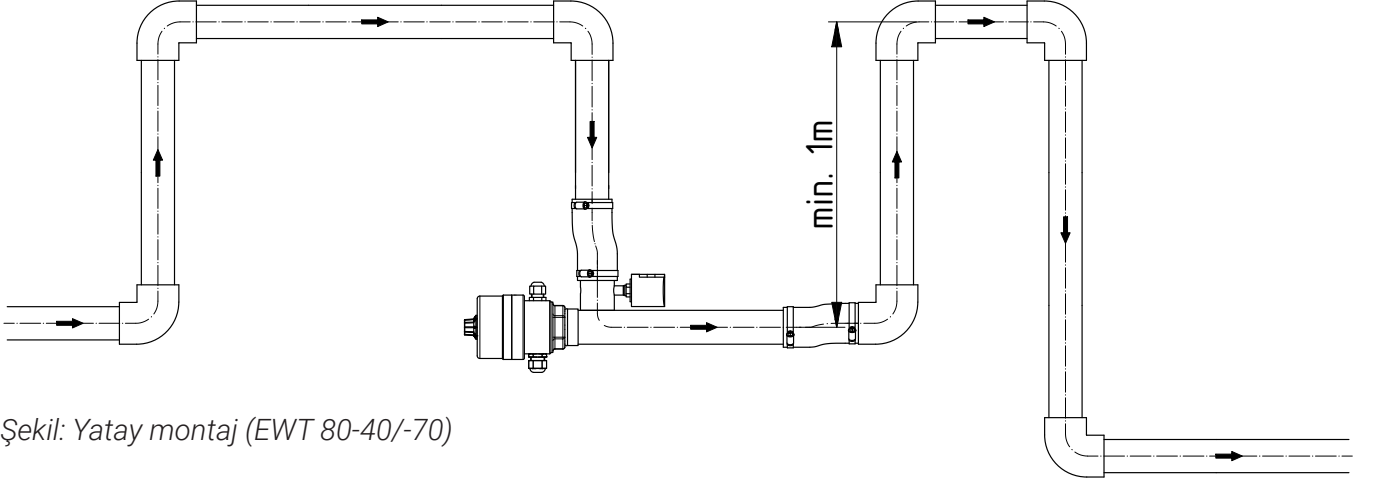

Şekil: Yatay montaj (EWT 80-40/-70)

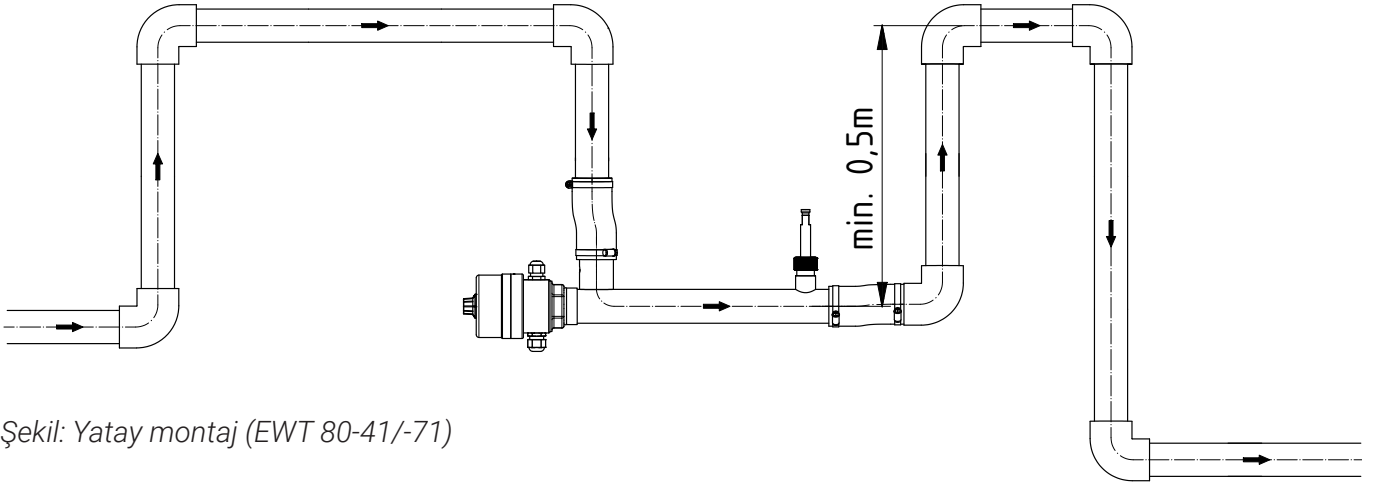

Şekil: Yatay montaj (EWT 80-41/-71)

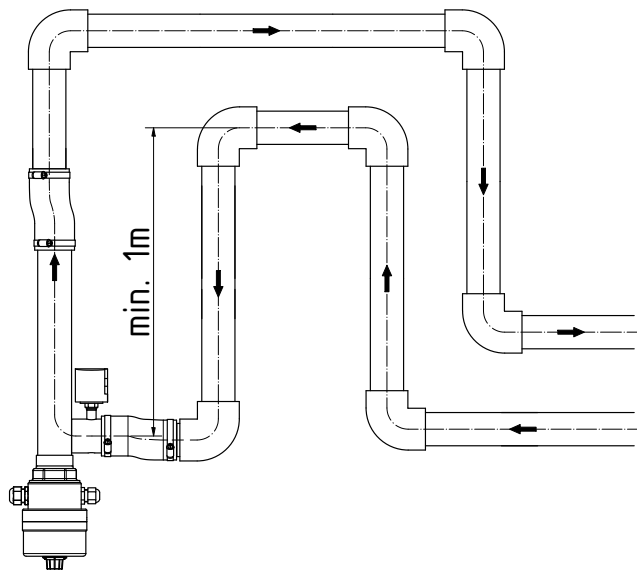

Şekil: Dikey montaj (EWT 80-40/-70)

## 2.4.2 Su seviyesi altındaki kurulum düzenlemesi

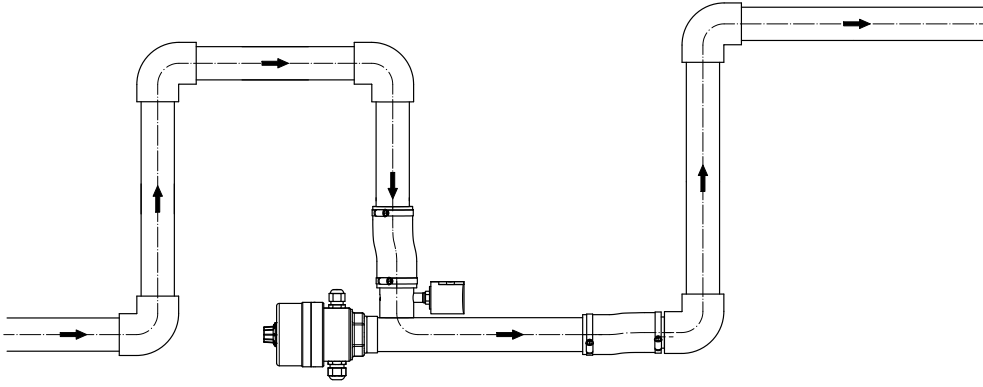

Şekil: Yatay montaj (EWT 80-40/-70)

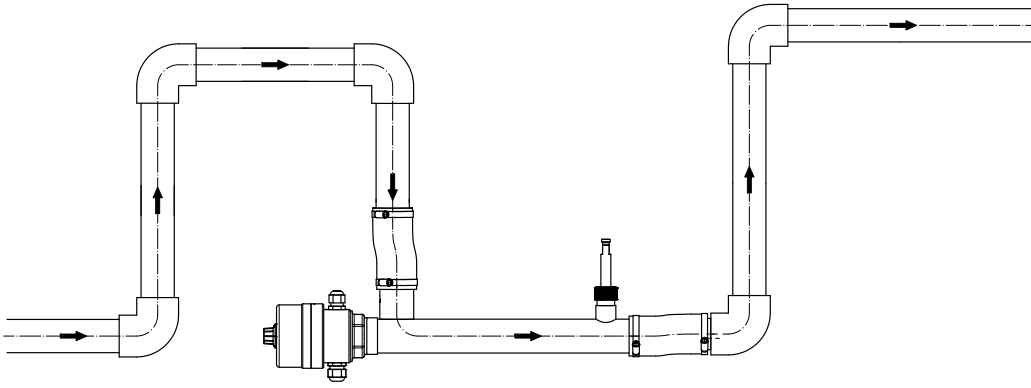

Şekil: Yatay montaj (EWT 80-41/-71)

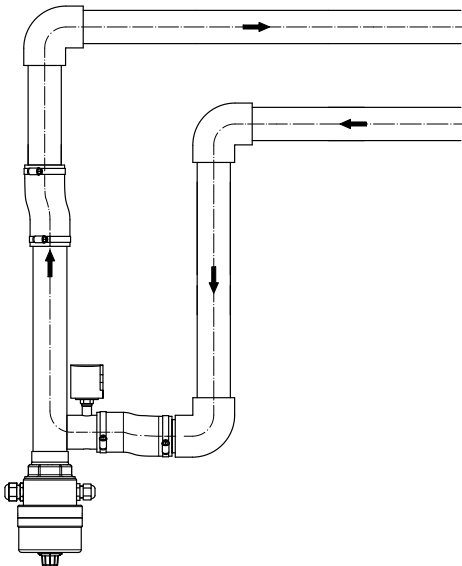



Şekil: Dikey montaj (EWT 80-40/-70)

### 2.4.3 Elektro ısı eşanjörünün bir filtre sisteminin su devrine bağlantısı

Elektro ısı eşanjörünü (havuza giden) basınçlı hatta pompa ve filtreden sonra monte edin.

EWT 80-40/-41, su devrine 1 1/2" iç dişler üzerinden veya hortum kelepçeleriyle hortum bağlantıları üzerinden bağlanır.

EWT 80-70/-71, su devrine PVC yapışkan kaplinlerle bağlanır.

	<p><b>DİKKAT!</b></p> <p>Elektro ısı eşanjörü hasar görebilir.</p> <p>Su devrine bağlantı yapılırken, ısı eşanjörünün içine metal parçaların sürüklenmemesine dikkat edilmemelidir.</p>
	<p><b>DİKKAT!</b></p> <p><b>Elektro ısı eşanjörü kimyasal maddelerden dolayı hasar görebilir.</b></p> <p>Aritma cihazları genel olarak akış yönünde elektro ısı eşanjöründen sonra kurulmalıdır. Uzaklık en az 1 m olmalıdır ve önce sertlik ayarı ile ardından klorla aşılama sırasına riayet edilmelidir.</p> <p>Kimyasal maddeler (örn. klor gazı) kullanıldığı takdirde, filtre durma süreleri esnasında elektro ısı eşanjörüne gaz sızmamalıdır.</p>

### 2.4.4 Akış şalteri için genel montaj hatırlatmaları

Akış kontrol şalterinin önü ve gerisindeki dengeleme mesafesi en az 5 x DN olmalıdır.

**Akış kontrol şalteri yalnızca yatay bir hattın içine monte edilebilir.**

Farklı montaj sistemlerinde üretici firmaya danışmalısınız.

Şalteri sadece dik durarak monte etmelisiniz, sapma maks. 45° (bkz. Şek. 1).

Akış kontrol şalterinin doğrudan çevresinde manyetik yabancı alanların cihazın çalışma şeklini etkilememesini sağlayın (bkz. Şek. 2).

Akış kontrol şalterinin üzerinde bir ok bulunmaktadır. Montaj sırasında bunun mutlaka boru eksenine paralel olmasına ve akış yönünü göstermesine dikkat edin (bkz. Şek. 3).

Plastik G 3/4 başlık somununu 8 Nm'lik bir maks. çekme torkuyla sıkmalısınız.



Abb. 1



Abb. 2



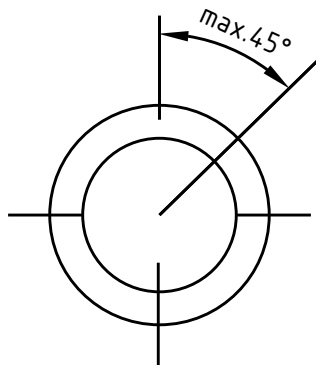



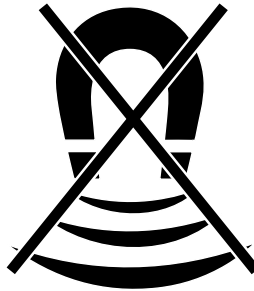

Abb. 3

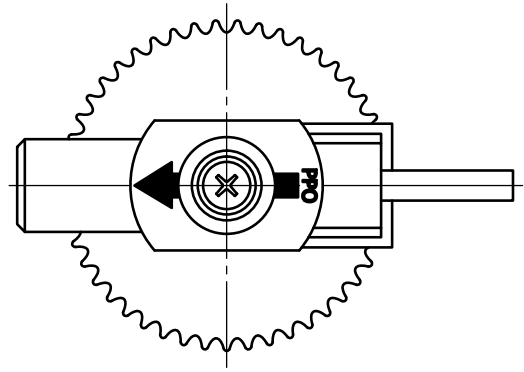
## 2.5 Elektrik bağlantısı

	<p><b>ELEKTRİK GERİLİMİ!</b></p> <p>Elektrik bağlantısı sadece bir elektrik teknisyeni tarafından gerçekleştirilebilir. Bu sırada yasal talimatlar ve ayrıca VDE 0100 dikkate alınmalıdır. Isı eşanjörü devamlı olarak koruyucu iletkenli sabit döşenmiş hatlara bağlanmalıdır.</p>
	<p><b>DİKKAT!</b></p> <p><b>Elektro ısı eşanjörü en az iki emniyet anahtarıyla korunmalıdır.</b></p> <p>Fabrikadan aşağıdaki kombinasyonlar sunulmaktadır</p> <ul style="list-style-type: none"><li>– bir ayar termostatu ile</li><li>– bir ayar termostatu ve bir emniyet sıcaklık sınırlandırıcısı (STB) ile</li><li>– bir ayar termostatu, bir STB ve bir akış şalteri ile.</li><li>– 12 kW'a kadar bir kontaktör ile.</li></ul> <p>Fabrikadan bir kontaktör kurulmamış ise, ısıtma çubuğunun anahtarlanması için harici bir kontaktör gereklidir (örn. EWT 80-xx için Behncke kumandası)</p>
	<p><b>HATIRLATMA!</b></p> <p>Elektro ısı eşanjörünün sadece akış emniyete alındığında açılabilirdiğinden emin olunmalıdır.</p> <p>Elektrik bağlantıları şemaya göre uygulanmalıdır. Güvenlik nedenlerinden dolayı gerilim beslemesine bir FI devre kesici (30 mA) monte edilmelidir. Tüm metal parçalar, eşpotansiyelli bağlamaya dahil edilmelidir.</p>

## 2.6 Akış şalteri

	<p><b>DİKKAT!</b></p> <p><b>Elektrik geriliminden dolayı hayati tehlike!</b></p> <p>Bağlantı hattının kablolarını bağlamadan önce elektrik sistemini gerilimsiz hale getirin.</p> <p>kahverengi/siyah = dilli kontağa ait bağlantılar</p> <p>Dilli kontak koruyucu izolasyonla (koruma sınıfı II) bir plastik kovana entegre edilmiştir.</p>
	<p><b>DİKKAT!</b></p> <p><b>Elektrik geriliminden dolayı hayati tehlike!</b></p> <p>Tip etiketinde belirtilen maks. elektrik kontak yükü kesinlikle aşılmamalıdır, aksi takdirde anahtarlama ünitesindeki entegre dilli kontak hasar görür. Endüktif yüklerde anahtarlama kapasitesi azalır. Koruma devresine ilişkin bilgiler üretici fabrikadan sorulabilir.</p>

### 3 Fonksiyon akışı

Elektro ısı eşanjöründe ısıtma çubuğu tarafından havuz suyuna ısı aktarılmaktadır.

Termostat, su sıcaklığını ayarlanan seviyede kontrol eder, ayar aralığı: 0 ila 40°C.

EWT 80-40/-70: Gereken aşırı çalışma basıncı eksik akıştan dolayı 6 kPa (0,06 bar) altına inerse, emniyet basınç sınırlandırıcısı elektro ısı eşanjörünü kapatır.

EWT 80-41/-71: Gereken aşırı çalışma basıncı eksik akıştan dolayı 36,0 l/dk. altına inerse, akış şalteri EWT'yi kapatır.

Seçenek: Emniyet termostadı

Emniyet sıcaklık sınırlandırıcısı aşırı ısınmaya karşı korur. Bu, 44°C'lık bir sıcaklıkta elektro ısı eşanjörünü kapatır.

Arıza giderme düğmesine basarak elektro ısı eşanjörü bir arızanın giderilmesinden sonra normal işletim hazırlığına tekrar getirilebilir.

### 4 Devreye alma

Özellikle Bölüm 1 Emniyet olmak üzere bu işletme talimatını okudunuz ve anladınız mı? Bunun öncesinde elektro ısı eşanjörünü devreye alamazsınız!

- İstenen havuz suyu sıcaklığını termostatta ayarlayın.

Ayarlanan sıcaklığa ulaşılmadığı sürece, elektro ısı eşanjörü havuz suyunu ısıtır.

	<p><b>DİKKAT!</b></p> <p><b>Elektro ısı eşanjörü hasar görebilir.</b></p> <p>Boru hatlarında ve elektrik tesisatındaki çalışmalar güvenlik nedenlerinden dolayı sadece uzman personel tarafından gerçekleştirilebilir.</p> <p>Elektro ısı eşanjörünün üzerine basmayın.</p> <p>Bakım ve temizlik çalışmalarını sadece su devriyle kilitleme organları kapalı olduğunda gerçekleştirin!</p> <p>Tüm su devrini havalandırın, aksi takdirde ısıtma elemanı hasar görebilir.</p>
---	--

### 5 Bakım / onarım

Her hafta elektro ısı eşanjörünü ve bağlantıları sızdırmazlık yönünden kontrol edin ve tüm su devrini havalandırın.

	<p><b>DİKKAT!</b></p> <p><b>Elektro ısı eşanjörü hasar görebilir.</b></p> <p>Elektro ısı eşanjöründeki çalışmalar güvenlik nedenlerinden dolayı sadece uzman personel tarafından gerçekleştirilebilir.</p> <p>Elektro ısı eşanjörünün üzerine basmayın.</p> <p>Boru bağlantılarındaki çalışmalar sadece su devirlerindeki kilitleme organları kapalıyken yapılabilir!</p>
---	---

## 5.1 EWT'nin kış mevsiminde donlanma olmayan odalarda saklanması

	<p><b>DİKKAT!</b></p> <p>Eğitimsiz kişiler tarafından teknik sisteme müdahaleler yaralanmalara ve maddi hasarlara neden olabilir.</p> <p>Donlanma olmayan odalarda çalışma durdurulduğu takdirde elektro ısı eşanjörü doldurulmuş veya komple boşaltılmış olmalıdır.</p>
---	--

## 5.2 EWT'nin kış mevsiminde donlanma tehlikesi olan odalarda saklanması

	<p><b>DİKKAT!</b></p> <p>Aşağıdaki çalışma adımlarına riayet edilmesi halinde, don hasarları olmadan kış mevsiminde doğru şekilde bir depolama mümkündür.</p> <ul style="list-style-type: none"><li>• Su devrindeki kilitleme organlarını kapatın. (Kilitleme organları donlanma olmayan odalarda kurulmuş olmalıdır.)</li><li>• Elektro ısı eşanjörünü ve kilitleme organlarına kadar bağlanan boru hatlarını yıkayın ve boşaltın.</li></ul>
---	---

### 5.2.1 Dikey düzende elektro ısı eşanjörü

Boşaltma armatürleri üzerinden elektro ısı eşanjörünü komple boşaltın.

### 5.2.2 EWT'nin kış mevsiminde yatay düzende saklanması

Yatay düzende elektro ısı eşanjörünü sökün.

Kirlenmeleri gidermek için elektro ısı eşanjörünü yıkayın ve kuru halde depolayın.

## 6 Arızalar ve çözümler

Hata	Olası nedenin kontrol edilmesi
Güç yok	Elektro ısı eşanjörü elektriğe bağlanmış mı? Su devrindeki kilitleme organları açık mı? Elektro ısı eşanjörü komple suyla doldurulmuş mu? Elektro ısı eşanjörü havalandırıldı mı?
Havuz suyunun sirkülasyon pompası kapalı olmasına rağmen, elektro ısı eşanjörünün ısıtılması devam eder	Elektro ısı eşanjöründen yeterince su akıyor mu (bkz. Teknik veriler)? Havuz suyu pompasıyla elektro ısı eşanjörü arasındaki kilit aktif mi?

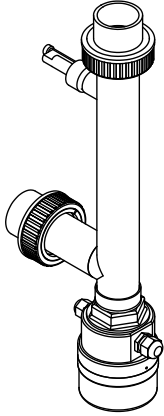

**Elektro Wärmetauscher**

**Technische Abbildungen**  
**Technical illustrations**  
**Illustrations techniques**  
**Illustrazioni tecniche**  
**Technische illustraties**  
**Технические иллюстрации**  
**Ilustraciones técnicas**  
**Teknik çizimler**  
**EWT-80-40/-41**  
**EWT-80-70/-71**

## Elektro Wärmetauscher

Technische Abbildungen / Technical illustrations / Illustrations techniques / Illustrazioni tecniche /  
Technische illustraties / Технические иллюстрации / Ilustraciones técnicas / Teknik çizimler

Artikel	Leistung [kw]	Versorgungsspannung [Volt]	Temperaturwahl [C°]	Artikel-Nr.
EWT 80-40	1,5	230	0 - 40	304 501 50
EWT 80-40	3	400	0 - 40	304 503 00
EWT 80-40	6	400	0 - 40	304 506 00
EWT 80-40	9	400	0 - 40	304 509 00
EWT 80-40	12	400	0 - 40	304 512 00
EWT 80-40	15	400	0 - 40	304 515 00
EWT 80-40	18	400	0 - 40	304 518 00

### EWT 80-40 – Muffe für Schlauch und Gewinde 1 1/2"

EWT 80-40 – Socket for hose and thread 1 1/2"

EWT 80-40 – manchon pour tuyau et filetage 1 1/2"

EWT 80-40 – calotta per tubo flessibile e filettatura 1 1/2"

EWT 80-40 – Mof voor slang en draad 1 1/2"

EWT 80-40 – Муфта для шланга и резьбы 1 1/2"

EWT 80-40 – Manguito para manguera y rosca 1 1/2"

EWT 80-40 – Hortum ve diş 1 1/2" için manşon

Artikel	Leistung [kw]	Versorgungsspannung [Volt]	Temperaturwahl [C°]	Artikel-Nr.
EWT 80-41	1,5	230	0 - 40	304 401 50
EWT 80-41	3	400	0 - 40	304 403 00
EWT 80-41	6	400	0 - 40	304 406 00
EWT 80-41	9	400	0 - 40	304 409 00
EWT 80-41	12	400	0 - 40	304 412 00
EWT 80-41	15	400	0 - 40	304 415 00
EWT 80-41	18	400	0 - 40	304 418 00

### EWT 80-41 – Muffe für Schlauch und Gewinde 1 1/2", mit Strömungsschalter

EWT 80-41 – Socket for hose and thread 1 1/2", with flow switch

EWT 80-41 – manchon pour tuyau et filetage 1 1/2", avec interrupteur de débit

EWT 80-41 – calotta per tubo flessibile e filettatura 1 1/2", con sensore di flusso

EWT 80-41 – Mof voor slang en draad 1 1/2", met stromingsschakelaar

EWT 80-41 – Муфта для шланга и резьбы 1 1/2", с реле потока

EWT 80-41 – Manguito para manguera y rosca 1 1/2", con interruptor de caudal

EWT 80-41 – Hortum ve diş 1 1/2" için manşon, akış şalteri ile

Artikel	Leistung [kw]	Versorgungsspannung [Volt]	Temperaturwahl [C°]	Artikel-Nr.
EWT 80-70	1,5	230	0 - 40	304 501 57
EWT 80-70	3	400	0 - 40	304 503 07
EWT 80-70	6	400	0 - 40	304 506 07
EWT 80-70	9	400	0 - 40	304 509 07
EWT 80-70	12	400	0 - 40	304 512 07
EWT 80-70	15	400	0 - 40	304 515 07
EWT 80-70	18	400	0 - 40	304 518 07

**EWT 80-70 – Regelthermostat und STB***EWT 80-70 – Control thermostat and safety temperature limiter**EWT 80-70 – avec thermostat régulateur de température et limiteur de température**EWT 80-70 – Termostato di controllo e LTS**EWT 80-70 – Regelthermostaat en STB**EWT 80-70 – Регулирующий термостат и предохранительный ограничитель температуры**EWT 80-70 – Termostato de regulación y STB**EWT 80-70 – Ayar termostati ve STB*

Artikel	Leistung [kw]	Versorgungsspannung [Volt]	Temperaturwahl [C°]	Artikel-Nr.
EWT 80-71	1,5	230	0 - 40	304 401 57
EWT 80-71	3	400	0 - 40	304 403 07
EWT 80-71	6	400	0 - 40	304 406 07
EWT 80-71	9	400	0 - 40	304 409 07
EWT 80-71	12	400	0 - 40	304 412 07
EWT 80-71	15	400	0 - 40	304 415 07
EWT 80-71	18	400	0 - 40	304 418 07

**EWT 80-71 – PVC-Klebeverschraubung d50, mit Strömungsschalter***EWT 80-71 – PVC adhesive fitting d50 with flow switch**EWT 80-71 – raccord à visser adhésifs en PVC d50, avec interrupteur de débit**EWT 80-71 – accordi a vite adesivi d50 in PVC con sensore di flusso**EWT 80-71 – Zelfklevende PVC-schroefverbinding d50, met stromingsschakelaar**EWT 80-71 – Клеевой фитинг d50, с реле потока**EWT 80-71 – Atornillamiento adhesivo de PVC d50, con interruptor de caudal**EWT 80-71 – PVC yapışkan kaplin d50, akış şalteri ile*

## Elektro Wärmetauscher

Technische Abbildungen / Technical illustrations / Illustrations techniques / Illustrazioni tecniche /  
Technische illustraties / Технические иллюстрации / Ilustraciones técnicas / Teknik çizimler

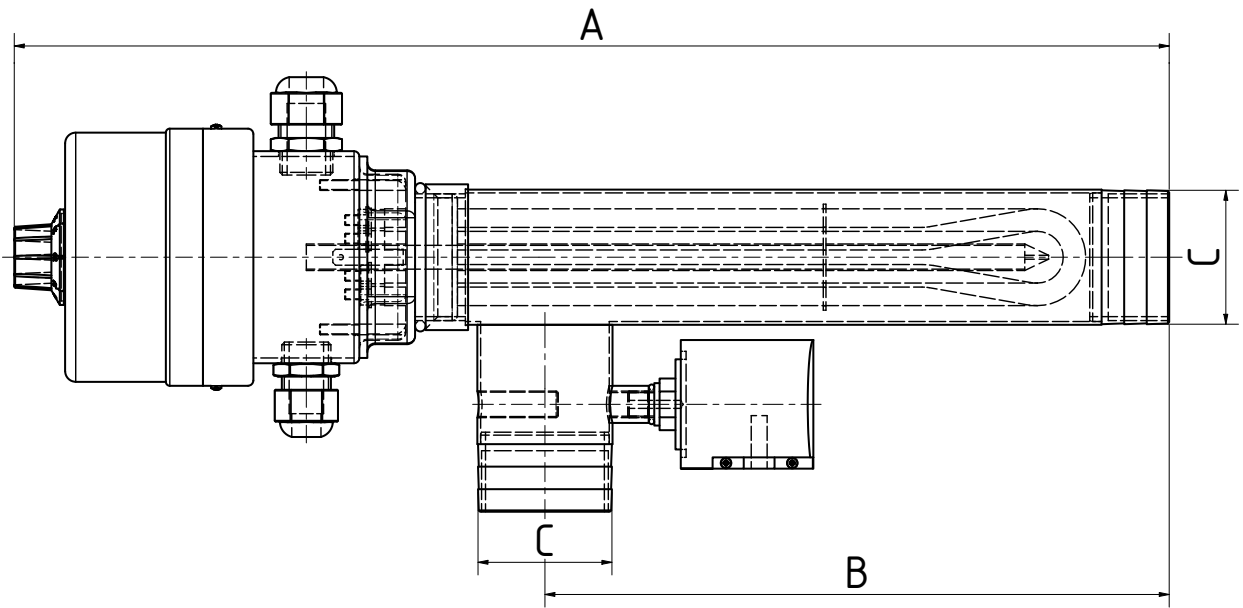

Artikel	Leistung [kw]	A [mm]	B [mm]	C* [Ø Zoll]
EWT 80-40	1,5	330	130	1 1/2
EWT 80-40	3	440	240	1 1/2
EWT 80-40	6	510	310	1 1/2
EWT 80-40	9	510	310	1 1/2
EWT 80-40	12	600	400	1 1/2
EWT 80-40	15	800	600	1 1/2
EWT 80-40	18	800	600	1 1/2

\* Muffe für Schlauch und Gewinde  
Socket for hose and thread  
Manchon pour tuyau et filetage  
Calotta per tubo flessibile e filettatura  
Mof voor slang en draad  
Муфта для шланга и резьбы  
Manguito para manguera y rosca  
Hortum ve diş için manşon

### Technische Daten EWT 80-40

Technical data for EWT 80-40  
Caractéristiques techniques EWT 80-40  
Dati tecnici EWT 80-40  
Technische gegevens EWT 80-40  
Технические характеристики EWT 80-40  
Datos técnicos EWT 80-40  
EWT 80-40 teknik veriler

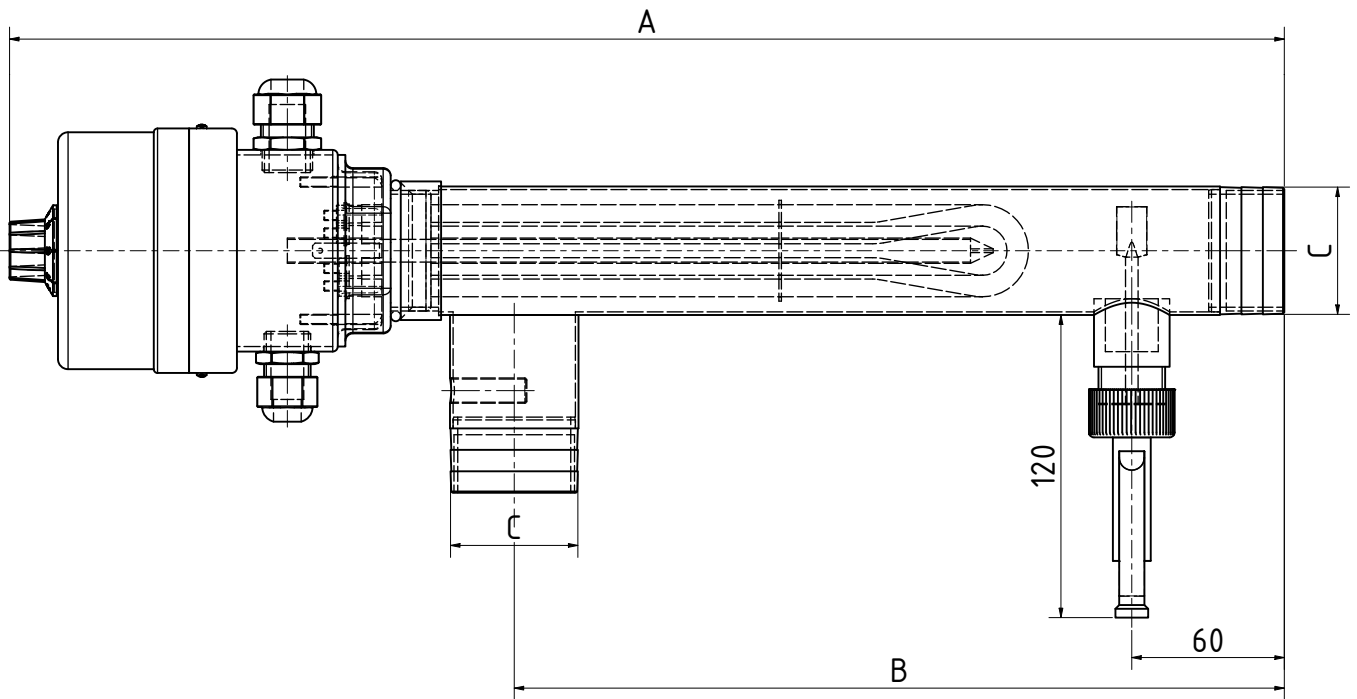

Artikel	Leistung [kw]	A [mm]	B [mm]	C* [Ø Zoll]
EWT 80-41	1,5	400	200	1 1/2
EWT 80-41	3	510	310	1 1/2
EWT 80-41	6	580	380	1 1/2
EWT 80-41	9	580	380	1 1/2
EWT 80-41	12	670	470	1 1/2
EWT 80-41	15	870	670	1 1/2
EWT 80-41	18	870	670	1 1/2

\* Muffe für Schlauch und Gewinde  
 Socket for hose and thread  
 Manchon pour tuyau et filetage  
 Calotta per tubo flessibile e filettatura  
 Mof voor slang en draad  
 Муфта для шланга и резьбы  
 Manguito para manguera y rosca  
 Hortum ve diğ için manşon

#### Technische Daten EWT 80-41

Technical data for EWT 80-41

Caractéristiques techniques EWT 80-41

Dati tecnici EWT 80-41

Technische gegevens EWT 80-41

Технические характеристики EWT 80-41

Datos técnicos EWT 80-41

EWT 80-41 teknik veriler

## Elektro Wärmetauscher

Technische Abbildungen / Technical illustrations / Illustrations techniques / Illustrazioni tecniche /  
Technische illustraties / Технические иллюстрации / Ilustraciones técnicas / Teknik çizimler

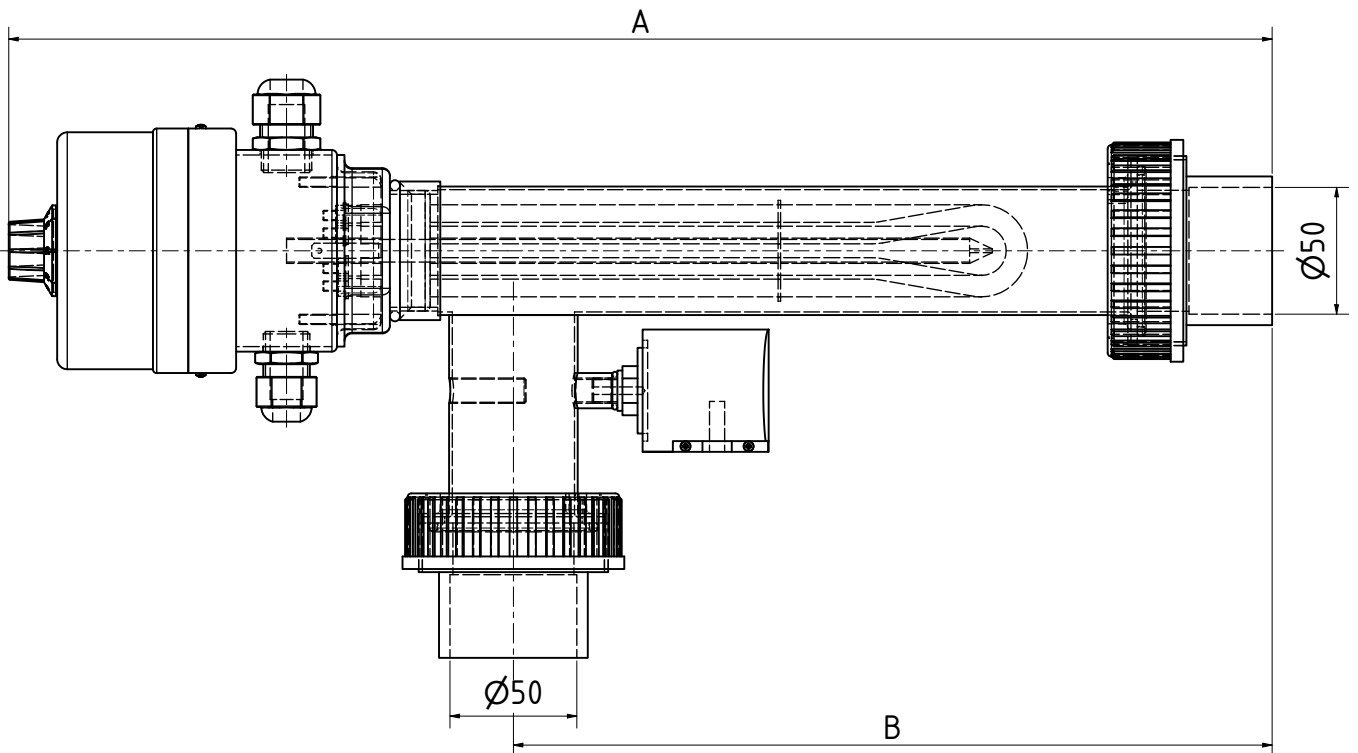

Artikel	Leistung [kw]	A [mm]	B [mm]
EWT 80-70	1,5	380	180
EWT 80-70	3	490	290
EWT 80-70	6	560	360
EWT 80-70	9	560	360
EWT 80-70	12	650	450
EWT 80-70	15	850	650
EWT 80-70	18	850	650

\* Muffe für Schlauch und Gewinde  
Socket for hose and thread  
Manchon pour tuyau et filetage  
Calotta per tubo flessibile e filettatura  
Mof voor slang en draad  
Муфта для шланга и резьбы  
Manguito para manguera y rosca  
Hortum ve diş için manşon

### Technische Daten EWT 80-70

Technical data for EWT 80-70  
Caractéristiques techniques EWT 80-70  
Dati tecnici EWT 80-70  
Technische gegevens EWT 80-70  
Технические характеристики EWT 80-70  
Datos técnicos EWT 80-70  
EWT 80-70 teknik veriler

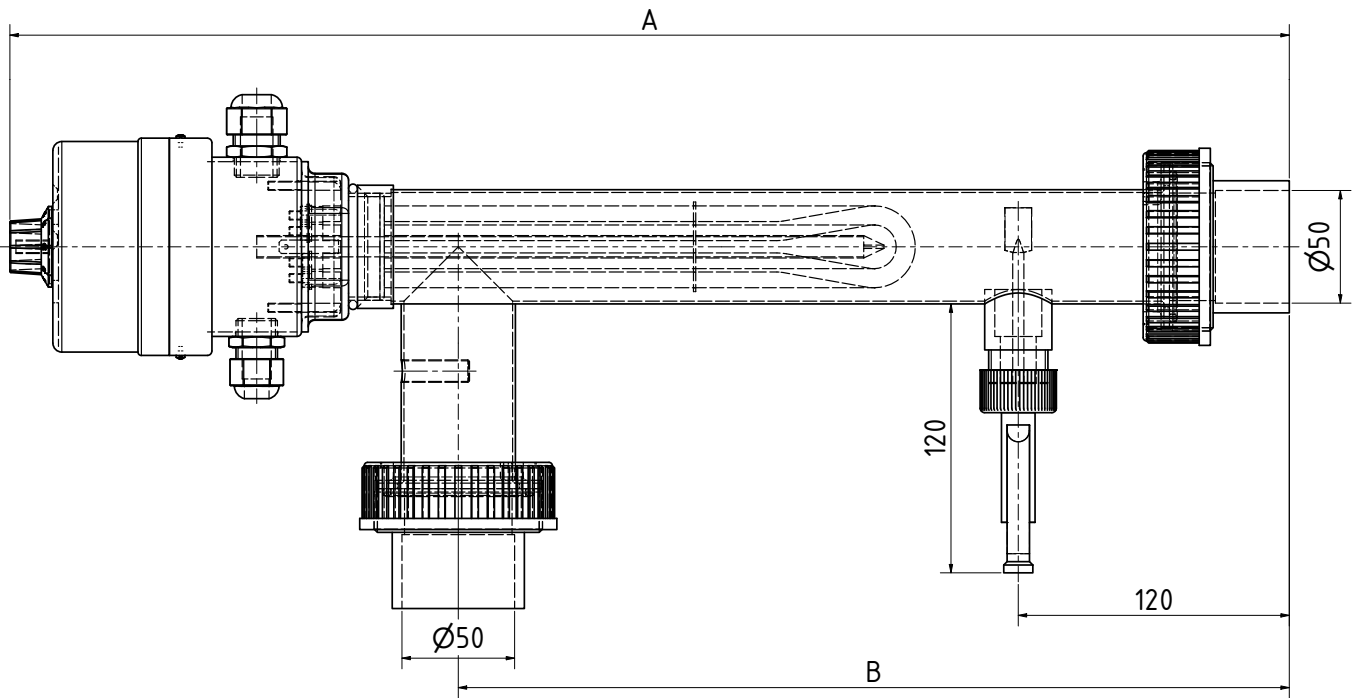

Artikel	Leistung [kw]	A [mm]	B [mm]
EWT 80-71	1,5	450	250
EWT 80-71	3	560	360
EWT 80-71	6	630	430
EWT 80-71	9	630	430
EWT 80-71	12	720	520
EWT 80-71	15	920	720
EWT 80-71	18	920	720

\* Muffe für Schlauch und Gewinde  
 Socket for hose and thread  
 Manchon pour tuyau et filetage  
 Calotta per tubo flessibile e filettatura  
 Mof voor slang en draad  
 Муфта для шланга и резьбы  
 Manguito para manguera y rosca  
 Hortum ve diş için manşon

**Technische Daten EWT 80-71**

Technical data for EWT 80-71  
 Caractéristiques techniques EWT 80-71  
 Dati tecnici EWT 80-71  
 Technische gegevens EWT 80-71  
 Технические характеристики EWT 80-71  
 Datos técnicos EWT 80-71  
 EWT 80-71 teknik veriler



# Elektro Wärmetauscher

Technische Abbildungen / Technical illustrations / Illustrations techniques / Illustrazioni tecniche / Technische illustraties / Технические иллюстрации / Ilustraciones técnicas / Teknik çizimler

Schaltbild 1

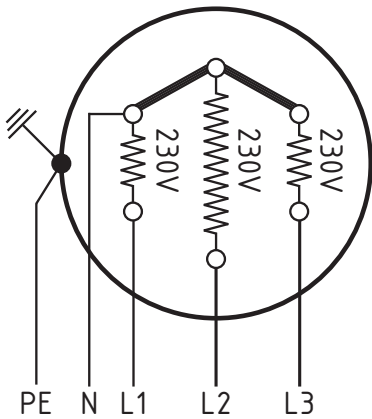

Y-Schaltung  
für 3x400V (Drehstrom)

Schaltbild 2

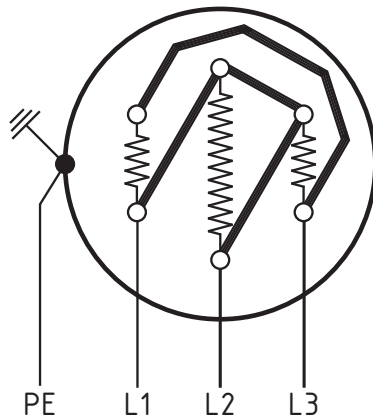

Δ-Schaltung  
für 3x230V (Drehstrom)

Schaltbild 3

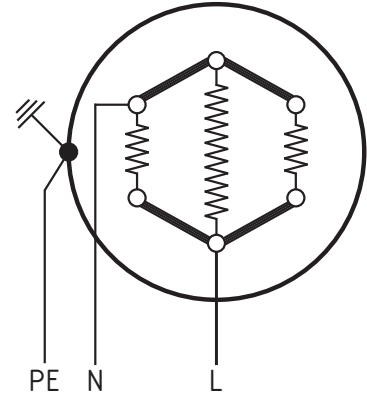

Schaltung bis max. 6kW  
für 1x230V (Wechselstrom)

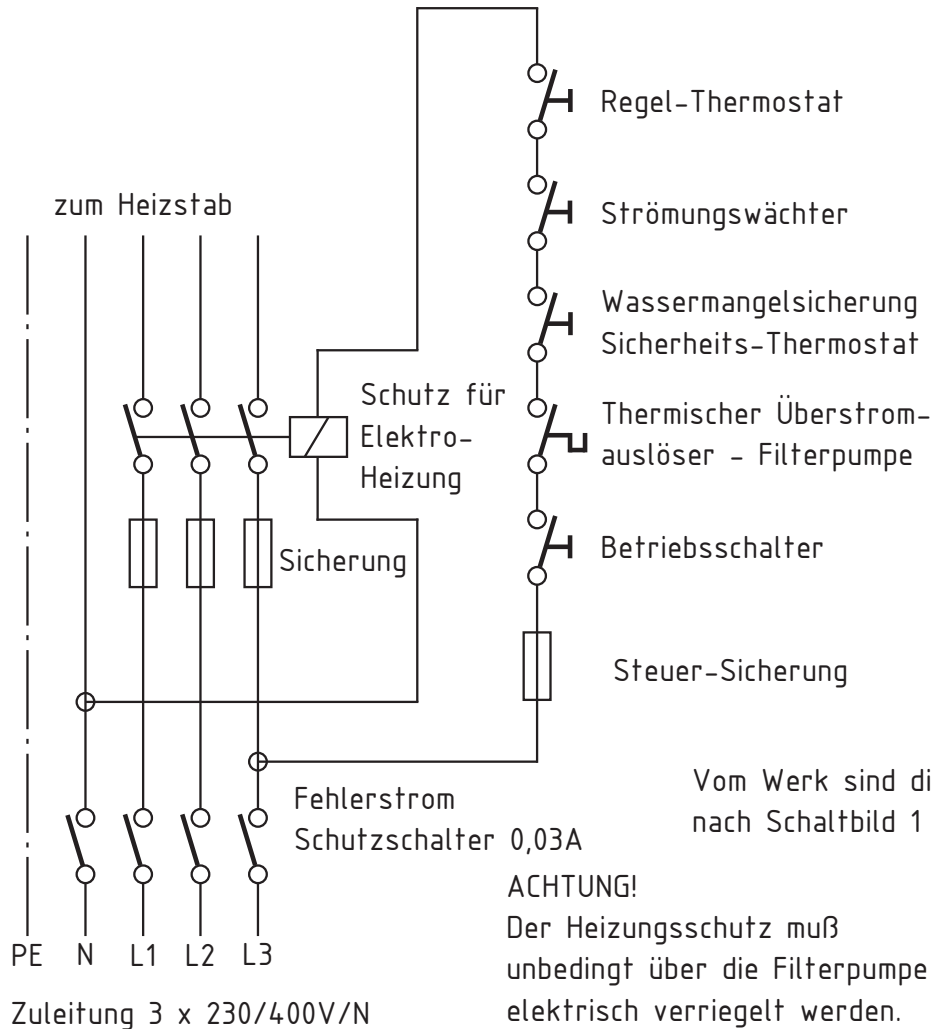

## Schaltplan EWT 80-40

Circuit diagram EWT 80-40

Schéma électrique EWT 80-40

Schema elettrico EWT 80-40

Schakelschema EWT 80-40

Схема электрических соединений EWT 80-40

Esquema de conexiones EWT 80-40

EWT 80-40 devre şeması

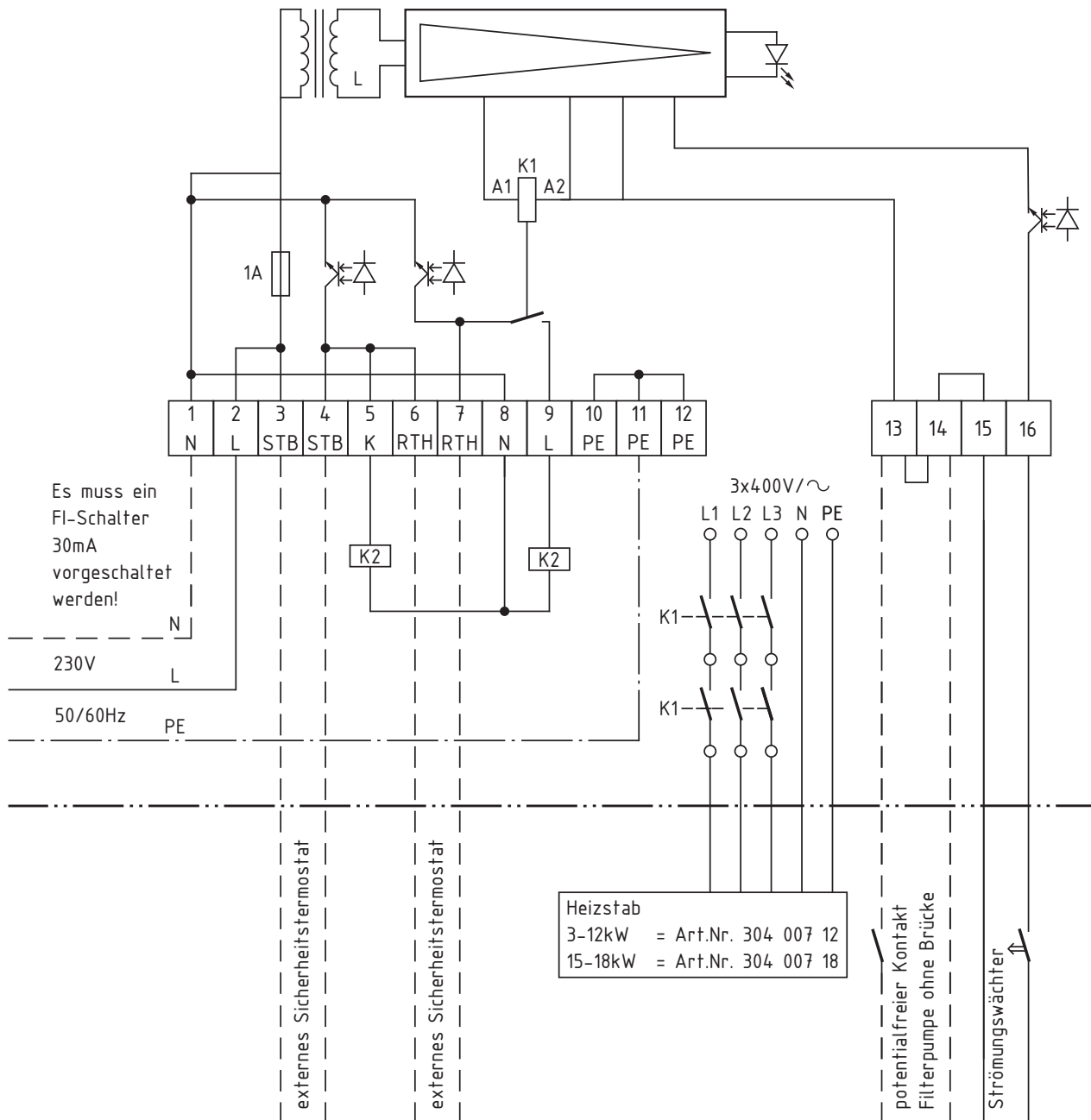

Achtung: EWT 80-41/71 immer mit Sicherheitsthermostat bestellen, ansonsten erfolgt keiner Sicherheitsabschaltung

Bi-LED grün	= Alles OK
Bi-LED grün, langsam blinkend	= Alles OK, Heizung an
Bi-LED grün, schnell blinkend	= 2 Minuten Wartezeit
Bi-LED rot an	= Übertemperatur!
Bi-LED rot, langsam blinkend	= über 2 Minuten keine Strömung
Bi-LED aus	= Kein Netz oder Strömungswächter aus und Sollwert erreicht

### Schaltkasten für EWT 80-41/-71/Titan

Control box for EWT 80-41/-71/Titanium

Coffret électrique pour EWT 80-41/-71/titane

Quadro elettrico per EWT 80-41/-71/titanio

Schakelkast voor EWT 80-41/-71/Titaan

Распределительная коробка для EWT 80-41/-71/титан

Armario de conexiones para EWT 80-41/-71/Titan

EWT 80-41/-71/Titan için şalter kutusu

## Elektro Wärmetauscher

Technische Abbildungen / Technical illustrations / Illustrations techniques / Illustrazioni tecniche /  
Technische illustraties / Технические иллюстрации / Ilustraciones técnicas / Teknik çizimler

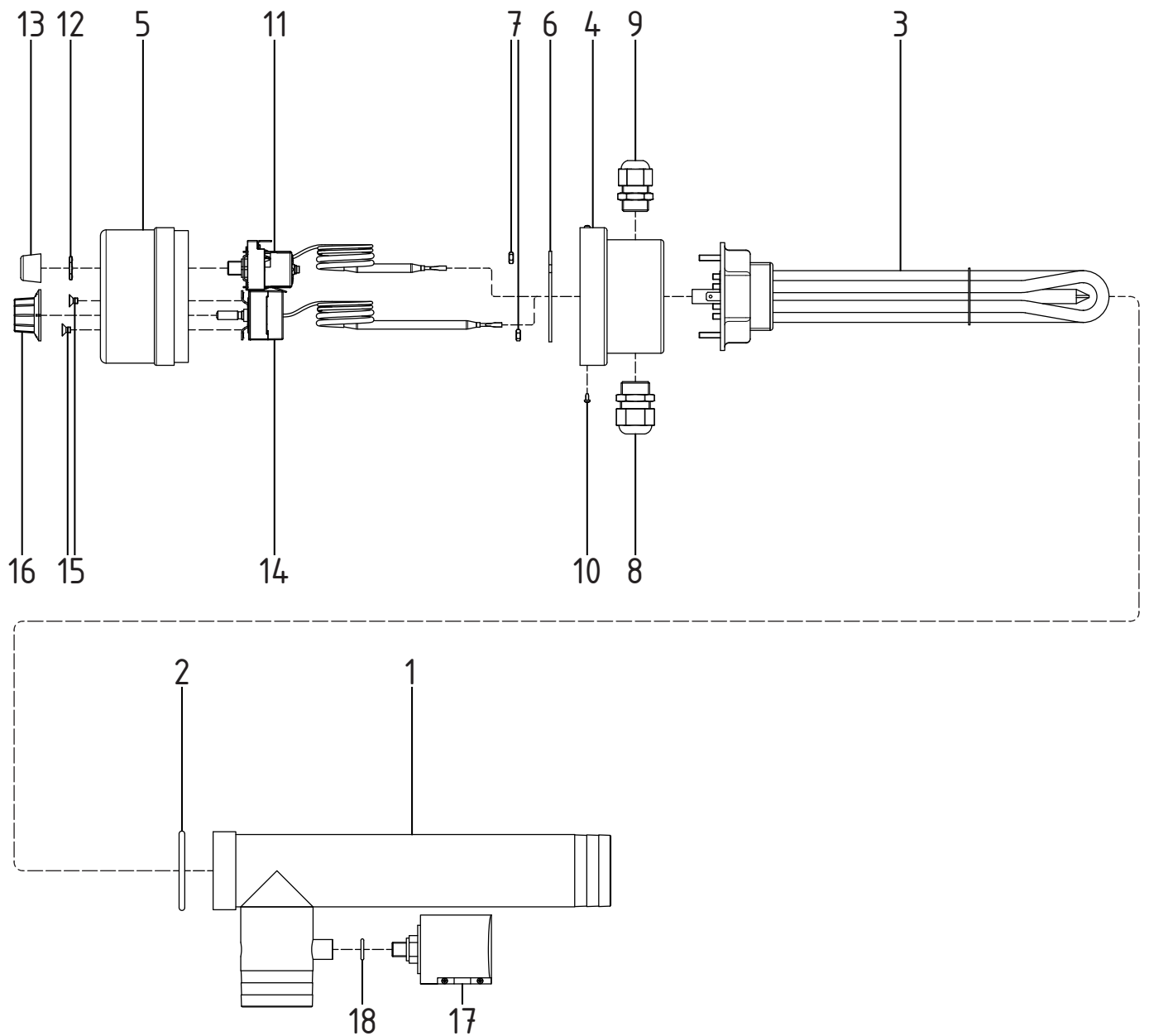

### Explosionszeichnung EWT 80-40

Exploded view of EWT 80-40

Représentation éclatée EWT 80-40

Vista esplosa EWT 80-40

Explosietekening EWT 80-40

Покомпонентное изображение EWT 80-40

Vista de despiece EWT 80-40

EWT 80-40 parça çizimi

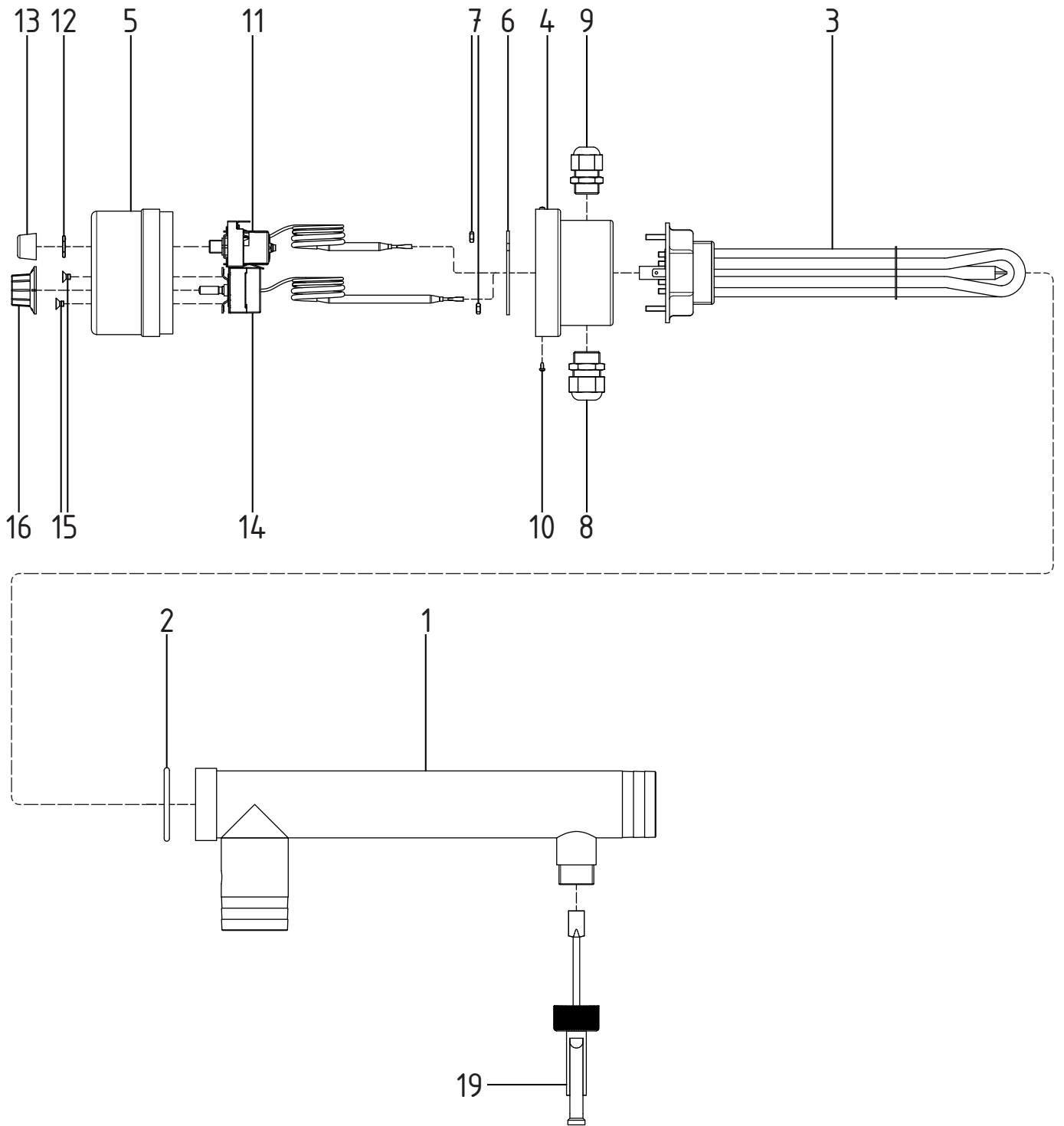

**Explosionszeichnung EWT 80-41**

*Exploded view of EWT 80-41*

*Représentation éclatée EWT 80-41*

*Vista esplosa EWT 80-41*

*Explosietekening EWT 80-41*

*Покомпонентное изображение EWT 80-41*

*Vista de despiece EWT 80-41*

*EWT 80-41 parça çizimi*



## Elektro Wärmetauscher

Technische Abbildungen / Technical illustrations / Illustrations techniques / Illustrazioni tecniche /  
Technische illustraties / Технические иллюстрации / Ilustraciones técnicas / Teknik çizimler

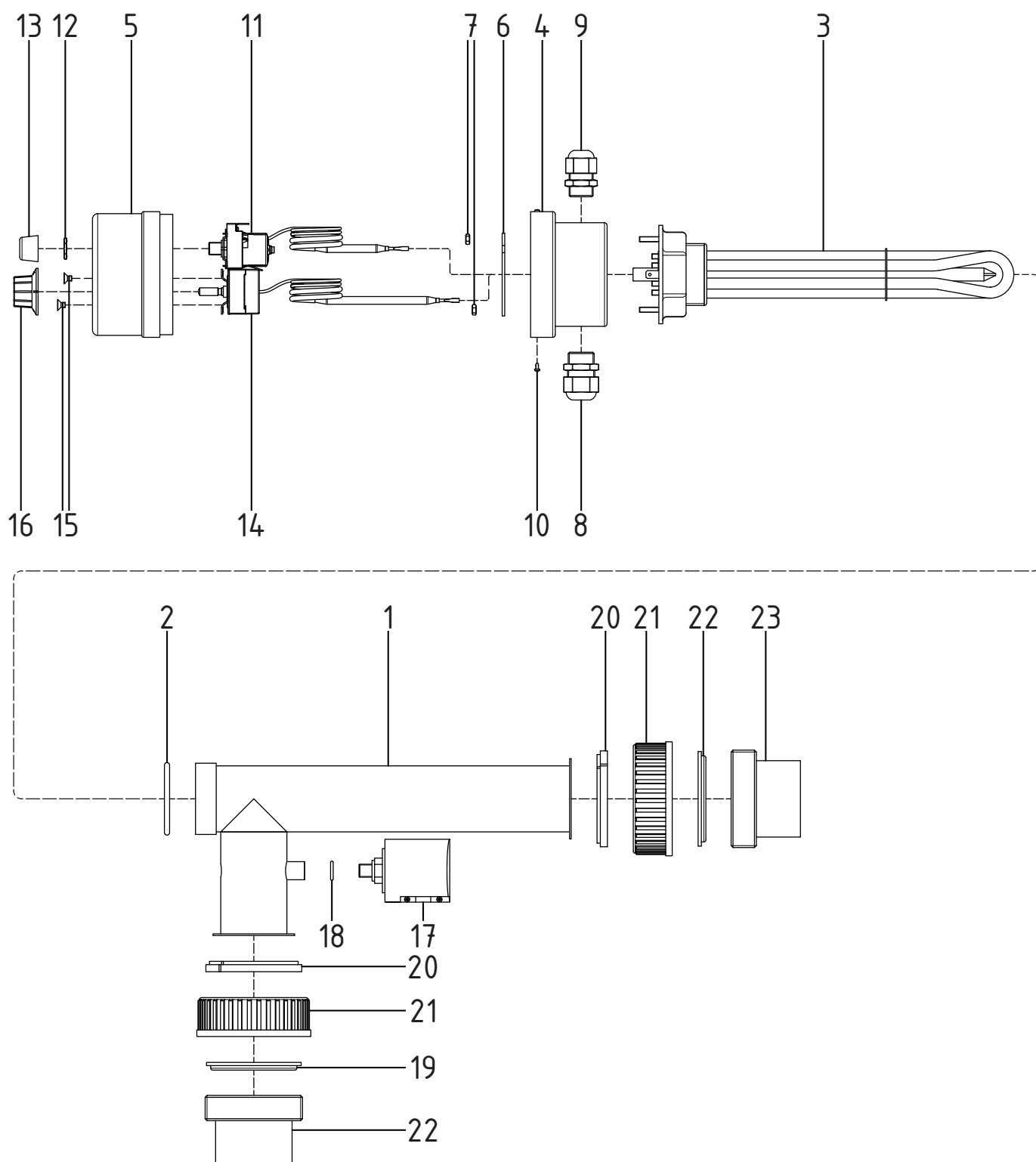

### Explosionszeichnung EWT 80-70

Exploded view of EWT 80-70

Représentation éclatée EWT 80-70

Vista esplosa EWT 80-70

Explosietekening EWT 80-70

Покомпонентное изображение EWT 80-70

Vista de despiece EWT 80-70

EWT 80-70 parça çizimi

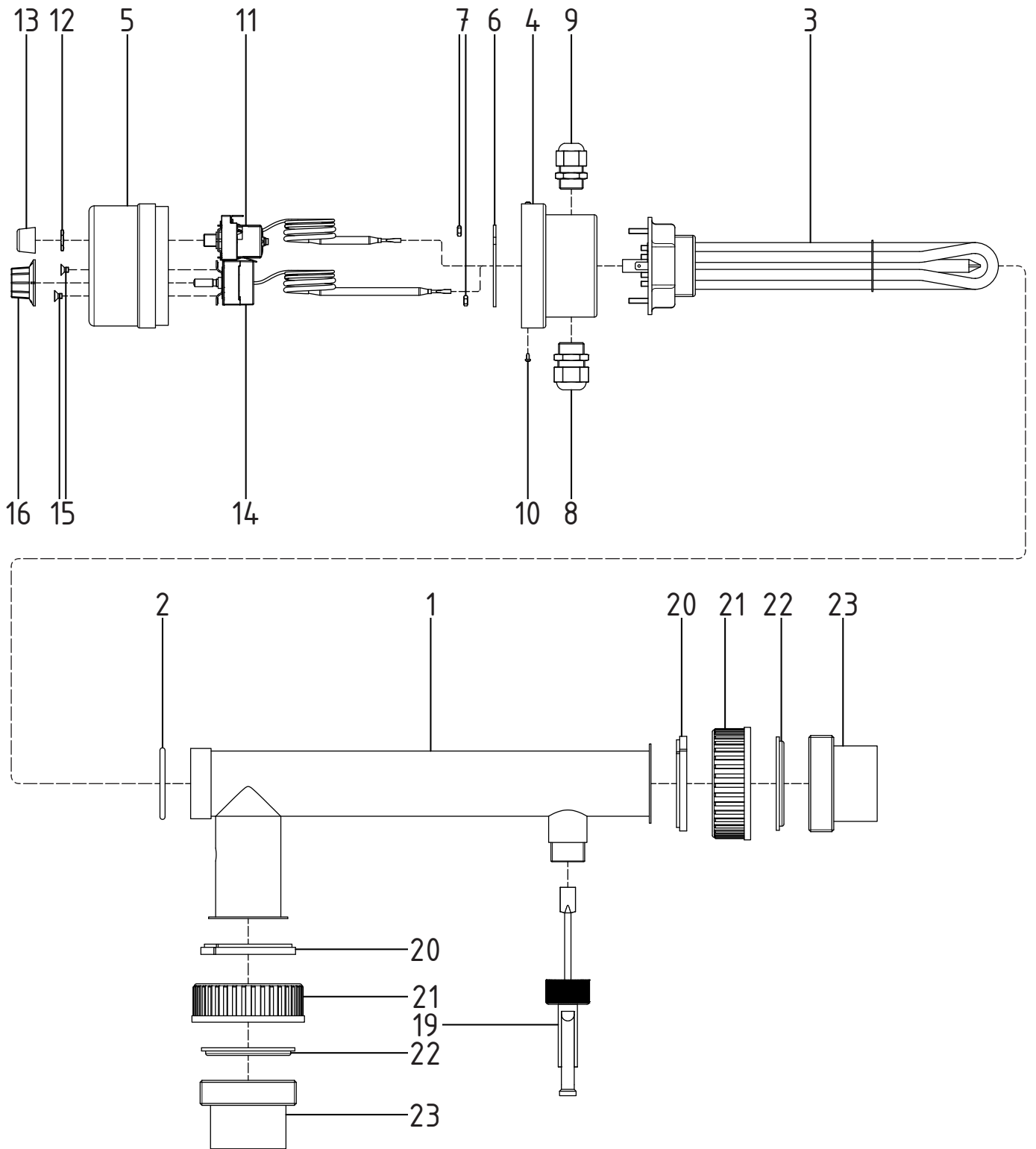

**Explosionszeichnung EWT 80-71**

*Exploded view of EWT 80-71*

*Représentation éclatée EWT 80-71*

*Vista esplosa EWT 80-71*

*Explosietekening EWT 80-71*

*Покомпонентное изображение EWT 80-71*

*Vista de despiece EWT 80-71*

*EWT 80-71 parça çizimi*



## Elektro Wärmetauscher

Technische Abbildungen / Technical illustrations / Illustrations techniques / Illustrazioni tecniche /  
Technische illustraties / Технические иллюстрации / Ilustraciones técnicas / Teknik çizimler

Pos.	Stück	Bezeichnung	Artikel-Nr.
1	1	Gehäuse, Edelstahl	---
2	1	O-Ring 44 x 4 NBR 75 Shore	304 021 01
3	1	Heizstab, Incoloy 825 - 1,5 kW	304 024 01
3	1	Heizstab, Incoloy 825 - 3 kW	304 024 02
3	1	Heizstab, Incoloy 825 - 6 kW	304 024 03
3	1	Heizstab, Incoloy 825 - 9 kW	304 024 04
3	1	Heizstab, Incoloy 825 - 12 kW	304 024 05
3	1	Heizstab, Incoloy 825 - 15 kW	304 024 06
3	1	Heizstab, Incoloy 825 - 18 kW	304 024 07
4	1	PVC-Kappe Unterteil	304 024 01
5	1	PVC-Kappe Oberteil	304 021 09
6	1	Befestigungsring, Edelstahl	---
7	2	Mutter M4	113 401 00
8	1	Kabelverschraubung PG 13,5/16/21	555 007 04/05/06
9	1	Kabelverschraubung PG 11	555 007 03
10	2	Blechschrabe 2,9 x 9,5	113 401 00
11	1	STB 51°C	304 021 02
12	1	Mutter, flach M10	---
13	1	PVC-Schraubabdeckung	---
14	1	Regelthermostat 0 - 40°C	304 021 11
15	2	Senkkopfschraube M4 x 6	113 392 10
16	1	Drehknopf für Regler	304 021 08
17	1	Wassermangelsicherung	391 033 00
18	1	O-Ring	---
19	1	Strömungsschalter VKX 05 M	304 001 07
20	2	ABS-Einlegeteil	304 200 01
21	2	ABS-Überwurfmutter	304 200 00
22	2	Flachdichtung EPDM	304 200 03
23	2	ABS-Anschlußteil	304 200 02

### Stückliste EWT 80-40/-41/-70/-71

Parts list for EWT 80-40/-41/-70/-71

Nomenclature EWT 80-40/-41/-70/-71

Elenco componenti EWT 80-40/-41/-70/-71

Stuklijst EWT 80-40/-41/-70/-71

Спецификация EWT 80-40/-41/-70/-71

Lista de piezas EWT 80-40/-41/-70/-71

EWT 80-40/-41/-70/-71 parça listesi

## EG-Konformitätserklärung

### Im Sinne der EG-Richtlinien

- Niederspannungsrichtlinie 2006/95/EG
- EMV- (elektronische Verträglichkeit) Richtlinie 2004/108/EG

Produkt: Elektro-Wärmetauscher  
Fabrikat: BEHNCKE® GmbH  
Typ: EWT 80-40/-41  
EWT 80-70/-71

Typenschild-Nr.:

Baujahr:

Diese Konformitätserklärung wurde in Übereinstimmung mit den aufgeführten EG-Richtlinien entwickelt, konstruiert und gefertigt, von der Firma

**BEHNCKE® GmbH**

**Betriebsteil Putzbrunn**

Michael-Haslbeck Str. 13

D-85640 Putzbrunn/München

#### Angewandte Normen:

- DIN EN ISO 13732-1 – Temperaturen berührbarer Oberflächen
- DIN 55014-1; VDE 0875-14-1 – Störaussendung
- DIN 55022; VDE 0878-22 – Funkstöreigenschaften - Grenzwerte und Messverfahren
- DIN 60730-2-7; VDE 0631-2-7 – Automatische elektrische Regel- und Steuergeräte für den Hausgebrauch und ähnliche Anwendungen
- DIN EN 60947-1; VDE 0660-100 – Niederspannungsschaltgeräte
- DIN EN 60335-2-35; VDE 0700-35 – (geändert 2012-04) Sicherheit elektr. Geräte für den Hausgebrauch und ähnliche Zwecke

Teil 2-35 Besondere Anforderungen für Durchflusserwärmer

- DIN EN 61000-4-2 – Prüfung der Störfestigkeit gegen Entladung statischer Elektrizität
- DIN EN 61000-4-4 – Prüfung der Störfestigkeit gegen schnelle transiente elektr. Störgrößen
- DIN EN 61000-4-8 – Prüfung der Störfestigkeit gegen netzfrequente Magnetfelder
- DIN EN 61000-4-9 – Prüfung der Störfestigkeit gegen impulsförmige Magnetfelder
- DIN EN 61010 – Sicherheitsanforderungen an elektr. Mess-, Steuer-, Regel- und Laborgeräte

Die zum Produkt gehörende Betriebsanleitung liegt vor. -in der Originalfassung deutsch

Putzbrunn

01.08.2022

C. Ebert, Betriebsleiter



Ort

Datum

Name/Unterzeichner und  
Angaben zum Unterzeichner

Unterschrift



**BEHNCKE® GmbH**

**Bayern:**

Michael-Haslbeck Straße 13  
D-85640 Putzbrunn

Fon: +49 (0)89 / 45 69 17-0  
Fax: +49 (0)89 / 45 69 17-61

**Sachsen-Anhalt:**

Stötterlinger Straße 36 a  
D-38835 Bühne

Fon: +49 (0)39421 / 796-0  
Fax: +49 (0)39421 / 796-30

**E-Mail:** [info@behncke.com](mailto:info@behncke.com)  
**Internet:** [www.behncke.com](http://www.behncke.com)

**BÖ-121**